

CPS-460 / 460DX / 460R
Ultrasonic
Doppler
Flowmeter

Instruction Manual
Series 'D', Rv 2020.2.7

CONTROL ELECTRONICS, INC.



Ship To Via UPS:

Control Electronics, Inc.
148 Brandamore Road
Brandamore, PA 19316

Mail to:

Control Electronics, Inc.
P.O. Box 330
Brandamore, PA 19316

Tel: 610-942-3190

Fax: 484-698-7771

<http://www.controlelectronics.com>

e-mail: cei@controlelectronics.com

INDEX

SPECIFICATIONS	IV.
REPAIR / RETURN POLICY	V.
PRODUCT PERFORMANCE STATEMENT	VI.
WARRANTY	VII.
... Please read first before installing flow meter.	
INTRODUCTION	1.
INSTALLING THE FLOWMETER	2.
1. CONTROLLER INSTALLATION	
Enclosure Location	2.
Conduit Entrances	3.
Enclosure Mounting	3.
2. SENSOR INSTALLATION	
Sensor Location	4.
Sensor Mounting	5.
3. ELECTRICAL CONNECTIONS	
Wiring Interconnect Overview	7.
Sensor Cable	8.
Power Connections	9.
AC Output	9.
DC Volt Outputs/Inputs	9.
Battery Operation	10.
Relay Outputs	11.
Sampler Pulse	11.
ZERO Meter Input	11.
4-20 mA Outputs	12.
Clock/Memory Battery	13.
CPS-460R Interconnect	Back of Manual
4. ADJUSTMENTS AND CONTROLS	
Transmitter / Receiver Card	
Tuning coils	14.
PreGain	14.
Threshold Adjust	14.
Flow Signal LED	14.
Low Pass Filter Adjust	15.
Cable Adjust	15.
GAIN Switch	15.
Main Circuit Board	
ON/OFF switch	15.
120/220VAC Select	15.
4-20mA. adjustments	15.
LED's 1 thru 5	15.
Running LED	15.
No Signal LED	15.
Clk/Mem 3V Battery	15.
STARTING UP THE FLOWMETER	16.
Check List	16.
Turning Power ON	16.

INDEX (CONT'D)

PROGRAMMING THE FLOWMETER	18.
LCD DISPLAY	
GPM, MGD, VELOCITY, TOTALIZER	18.
Measured Frequency	19.
Flow%, Signal Strength	19.
NF, FR, GD display	19.
BEGIN PROGRAMMING	
Pass Code	20.
Set Flow Parameters	20.
Site Cal Factor	20.
Testing The Relay Outputs	21.
Setting The Relay Outputs 1-4	21.
Setting The Sampler Pulse Output	21.
Setting Communications / Data Log	22.
RS-232 Baud Rate	22.
Data Log Sample Rate	22.
Testing the 4-20mA outputs	23.
Scale 4-20 mA Outputs	23.
Set 4-20 mA Damp Factor	23.
Set FLOW Type	24.
Setting The Time and Date	24.
Resetting the Totalizer and Data Log	24.
Sensor CAL Factor	24.
CHANGING THE CALIBRATION	24.
DATA LOGGING	25.
24 Hour Summary	25.
Viewing Daily Totals	25.
Print Daily Readings	25.
Average Flow Samples	26.
Event List	26.
Resetting The Data Log	26.
RESETTING THE FLOWMETER	27.
If Flowmeter Locks Up or Crashes	27.
USING THE PROGRAM FLOWCHART	
Operating Instructions	28.
Power Up Flowmeter	29.
RUN MODES	29.
Pass Code	29.
Setting FLOW PARAMETERS	30.
Test Relay Outputs	31.
Set Relay Outputs	31.
Sampler / External Counter Pulse	31.
Set Communications / Data Log	32.
Misc Settings	33.
Set TIME/DATE	33.
Reset TOTALIZER / DATA LOG	33.
Test 4-20 mA. Outputs	34.
Scale 4-20 mA Outputs	34.
Set 4-20 mA. Damp Factor	34.
Viewing the LOGGED Totals	35.
Print / Download DATA LOG	35.

INDEX (CONT'D)

USING RS-232 COMMUNICATION PORT	
Wiring Connections	36.
Saving Download To File	36.
Settings For Direct To PC COM Port 1 or 2	37.
Initiate DOWNLOAD from a PC	37.
MENU Selections	37.
USB Port	38.
APPLICATION GUIDE	39.
ILLUSTRATIONS	
Power Connections	9.
External Battery Connection	10.
Relay Outputs	11.
4-20 mA Connections	12.
3 Volt Battery Installation	13.
RS-232 Output Connections	36.
FIGURE 1. Enclosure Mounting / Dimensions	3.
FIGURE 2. Sensor Mounting	4-5.
FIGURE 3. Wiring Diagram	7.
FIGURE 4. Ultrasonic Xmit / Receive Card	14.
BACK OF MANUAL	
Trouble Shooting Guide	
CPS-460R Interconnect Back of Manual	



Electronics

Power Requirements: 120/220 VAC, $\pm 15\%$, 50/60 Hz
12-24 VDC @ 15W max.

Temperature: 30°F to 120°F

Display: 2 line x 20 character, Alphanumeric, LCD with LED backlighting

Totalizer: 8 digit accumulative with programmable multiplier; x1, x10, x100, x1000
200 daily, 8 digit totalizers

Outputs: Two (2) 4-20 mA isolated into 1000 ohm, RS-232 terminal, RJ11 modular jack, 5 relays - 4 control and 1 programmable pulse, SPDT 5A/250 VAC contacts

Flow Range*: 0.5-25.0 feet per second (FPS)

Sensitivity**: Minimum 75 ppm suspended solids and/or entrained gas/air bubbles

Display Resolution: 0.01 FPS, 0.01 GPM

Accuracy***: $\pm 0.5\%$ of received signal

Memory: Flash and nonvolatile RAM

Data Log: 200 day summary of Date, Daily Avg GPM, Total Pump Run Time, Total Pump Cycles, Total Gallons Pumped
Time Stamped Avg. GPM flow rate with programmable log rate of 00-99 minutes in 1 minute increments
Event List time stamped

Sensor (Dual-Head)

Material: PVC Housing, Epoxy

Temperature: -40°F to 160°F exposure

Cable: 25 foot corrosion resistant, 50 feet max.

Mounting: 1.0" to 72" pipe

Dimensions: 1.5"W x 2.0"L x 1.0"H (sensor head(s) only)

Type Pipes: Steel, PVC, Cast Iron, Most FRP and some lined pipes

Enclosure

Material: Fiberglass with clear hinged Polycarbonate cover

Rating: NEMA 4X, IP65, Dust-Tight, watertight, Corrosion Resistant, CSA, UL listed

Dimensions: 7.2"x11.8"x6.8"

Mounting: 4.92"x12.3" with stainless steel mounting feet

Options

Warranty: the CPS-460 system is pretested and inspected before shipping. Warranty is against defects in parts and workmanship for a period of one (1) year from ship date.

Specifications and design subject to change without notice. Made in USA.

* Flow velocities of approximately less than 1.0 FPS (± 0.5) not recommended

**Application Dependent - velocity/pipe may necessitate higher ppm

***Received signal is application dependent. Field/application conditions can affect apparent accuracy

DIMENSIONS

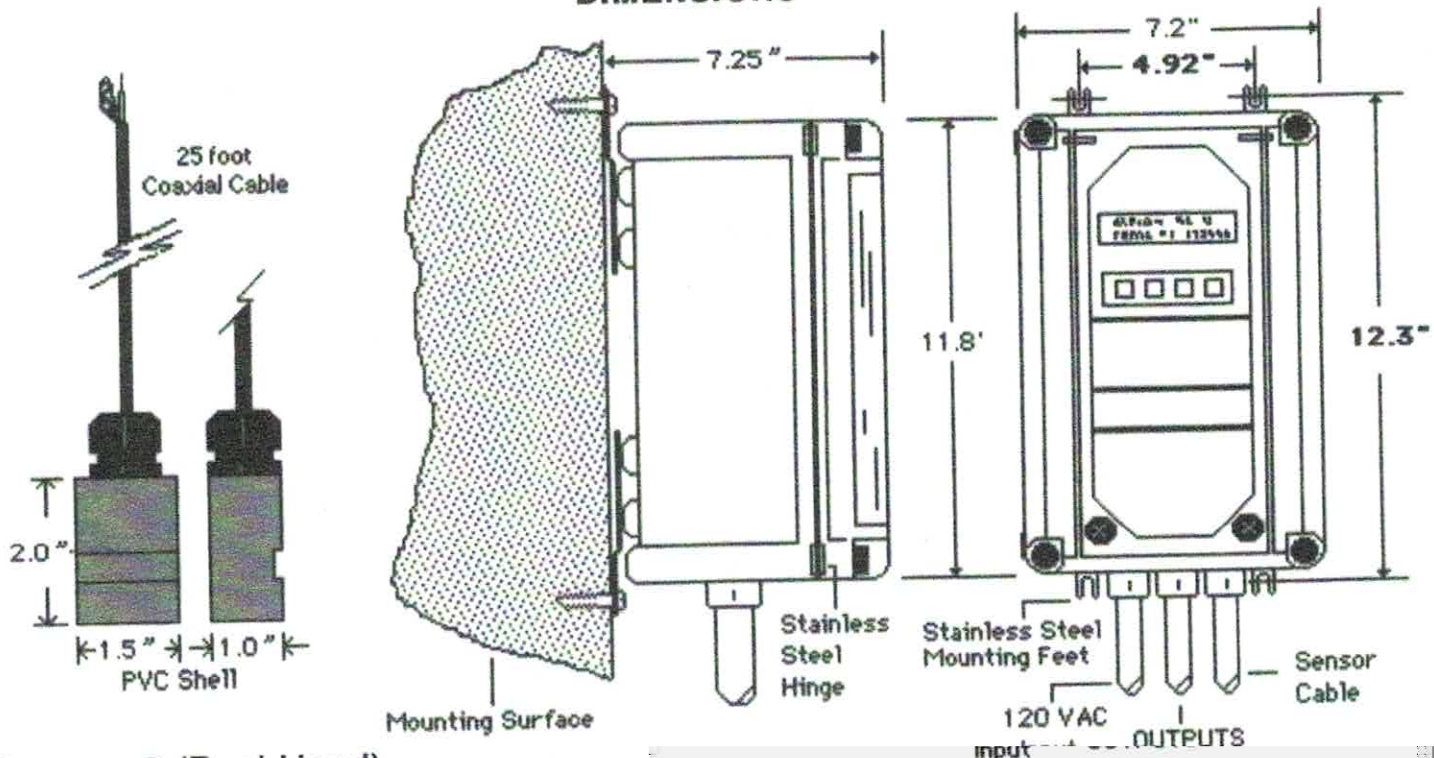

Sensor x2 (Dual Head)

Enclosure

Repair Policy: All repairs are performed on our premises. Repairs must be sent by UPS prepaid. **NO RMA** number is required. However ...

Customer must enclose:

- 1] a description of problem
- 2] who to contact
- 3] phone number
- 4] return ship-to address
- 5] **method of payment**, Credit Card or COD. A Company Purchase Order Number must be supplied if other payment method is to be arranged.
- 6] **Unit / Sensor must be cleaned** before shipping . We reserve the right to refuse repair or to apply a \$ 50.00 charge to repair of a product that has not been received cleaned.
Cleaned unit means removing any debris that may be clinging to the unit; wiping off loose dirt, cob webs, dead insects etc.

Delay of repair may occur if any of the above is not provided. Most repairs are processed and shipped within 48 hours of receiving repair.

Repair Cost: A minimal charge will be applied regardless of repair needed plus return shipping charges. If repair exceeds quoted minimal charge (call factory for quote), we will notify the customer before we proceed.

Payment is COD or Credit Card only unless other arrangements are made.

Warranty Repairs: Warranty repairs are made at our discretion and returned UPS GROUND at our expense.

Return Policy: We will accept 'return of product' for credit within 6 months of shipping date if it is determined that the product is not performing to specification as described in Product Performance statement in this manual (provided application is not the cause of problem). We do not accept returns for credit when the application is the source of the problem (i.e. poorly installed, poor piping arrangements, **interference from other equipment** etc.) , product is misapplied or not used properly and/or if product is out of warranty.

A **35% restocking charge** will be applied if the product is returned for credit after 6 months from ship date.

We do not accept returns of options such as used Sensors, cables, or spare parts unless shown to be defective under warranty or not performing as specified.

Any credit issued will be at our discretion. Warranty of product is limited only to the repair or replacement (with same model) of defective product.

Any product or part of product returned damaged will not be considered for any credit.

Customer must call for authorization before returning product for credit. Products returned for credit will not be considered without prior authorization.

A description of how it was determined that the product was not performing to specification must accompany the return of the product for our evaluation before we will consider any credit. The name of who to contact along with phone number should also be included with the return.

Packing: Repair/returned units must be packed (not loosely) in a suitable card board box with sufficient packing material (newspaper, packing peanuts etc.). We are not responsible for any product damaged through shipping. Make sure you insure the package for replacement cost. **DO NOT pack the unit upside down or sideways in the box.** Damage could result to product if you do.

CONTROL ELECTRONICS, INC.

CPS-460 Product Performance

Control Electronics CPS-460 Series will perform as specified when tested under known, simulated conditions. The accuracy of the product is determined by inputting a known frequency (± 1.0 Hz) into the system and monitoring its ability to process the information accurately. Specifications for the product are determined by this method.

The accuracy of the product is not determined by wet well drawdown test, pump curve charts etc. Such test indicate the accuracy of the overall application/installation, not just that of the product. Such tests are not acceptable as an indication of product(s) accuracy. However, draw-down test etc. can be used to determine if the calibration of the product should be changed from factory calibration to compensate for application/installation conditions. This should only be done if no other application/installation correction can be initiated to correct the problem.

Some equipment such as variable speed drives, nearby radio transmitters (i.e.: radio dispatch or hand held transmitters) etc. located next to the product or even at times in adjacent rooms may interfere with the products performance. The worst of these is the variable speed drive controllers. This type of equipment generates large amounts of electrical and RF (radio frequency) noise that can interfere with the products interpretation of the signal it is looking for and processing. Some adjustment to the product, relocation of the product or different electrical grounding arrangements may minimize or eliminate the interference. Ultimately, it is up to the user to make the corrections necessary and require that the product that is causing the interference be corrected.

If you have any questions in regards to product performance, please contact Control Electronics at (610) 942-3190.

You may also e-mail us at: cei@controlelectronics.com.

CONTROL ELECTRONICS, INC.

PRODUCT WARRANTY

WARRANTY:

Control Electronics, Inc. warrants to the buyer that its products are free from defects in materials and workmanship at the time of shipment and during the WARRANTY PERIOD. Control Electronics, Inc. obligation under this warranty is limited to the replacement of the product(s) by same product(s) manufactured by Control Electronics, Inc. or repair of the product(s) at the Control Electronics, Inc. facility. Control Electronics, Inc. products are sold with the understanding that the buyer has determined the applicability of the product(s) to its intended use. It is the responsibility of the buyer to verify acceptability of performance to the actual conditions of use. Performance may vary depending upon these actual conditions.

This Warranty is in lieu of any other warranty, expressed or implied. This includes, but is not limited to, any implied warranty of fitness for a particular purpose, or other obligations or liabilities on the part of Control Electronics, Inc. Under no circumstances will Control Electronics, Inc. be liable for any loss, damage, expense, or consequential damages of any kind arising in connection with the use, or inability for use, of Control Electronics, Inc. products.

WARRANTY PERIOD:

This warranty is in effect for twelve (12) months from the date of shipment from Control Electronics, Inc. place of business. Any extension of warranty period must be requested at time of purchase and made part of purchase order.

LIMITATIONS:

Control Electronics, Inc. products must be installed and maintained in accordance with Control Electronics, Inc. published instructions. Users are responsible for the suitability of the product(s) to their application. There is no warranty against damage resulting from corrosion, misapplication, improper specification, improper installation or any conditions beyond the control of Control Electronics, Inc. Claims against carriers for damage in transit must be filed by the buyer. Control Electronics, Inc. is not liable for labor costs incurred in removal, reinstallation, or unauthorized repair of its product(s). Control Electronics, Inc. warranty does not cover travel time or expenses for job site service. Requests for field service must be accompanied by a signed purchase order. Travel time and expenses will be charged to this purchase order, along with service time if the cause of the failure is not covered by the warranty. No service will be performed on any product(s) unless full payment has been made for product(s).

WARRANTY CLAIM:

If Control Electronics, Inc. products are found to be defective in materials or workmanship within twelve (12) months of the date of shipment, they will be repaired or replaced with same product at the discretion of Control Electronics, Inc. at its place of business at no charge to the buyer. The defective product(s) must be sent, freight prepaid, to the ship-to address on the front page of this manual for warranty claim. All claims must be made in writing. Enclose a brief description of problem, person to contact, phone number and return ship-to address. Product(s) received without this information may not be processed on a timely basis.

If warranty and/or product(s) is not acceptable to buyer, please contact Control Electronics, Inc. and/or return product(s) unused for credit. This action must be made within 60 days from ship date from Control Electronics, Inc. Installation of product(s) or non-response within 60 day period indicates the buyers acceptance of product(s) and above warranty.

NOTE

This manual covers both the CPS-460 and CPS-460DX Flowmeters. The CPS-460DX Flowmeter is the same as the CPS-460 system with the following exceptions.

The CPS-460DX system does not have:

- 1] Relay Outputs - no alarms or Sampler pulse
- 2] Clock or Date
- 3] RS-232 output port
- 4] Data Logging

This will be noted in the manual by - N/A on 460DX.

You may want to copy the following numbers from the upper left corner of the printed circuit board inside the enclosure for future reference. These numbers should be available if calling Control Electronics for tech support.

Serial Number:

Software Version:

Model Number:

INTRODUCTION

Control Electronics model CPS-460 Ultrasonic Closed Pipe Doppler Flowmeter is a non-contacting Flowmetering system engineered to accurately measure liquid flow through most full pipes, using high frequency Doppler techniques. The CPS-460 flowmeter has been designed with the user in mind, allowing for simple, intuitive programming through a menu driven interface. Control Electronics has been designing and manufacturing Ultrasonic Doppler flowmeters since 1980.

In theory, the CPS-460 Flowmetering system determines flow velocity in a pipe by calculating the difference between a transmitted, high-frequency sound wave through the pipe wall into the flow stream and the returned frequency that has been shifted as a result of reflecting off moving particles/ air bubbles suspended in the liquid. The system makes these measurements continuously and without contact to the flow. The increase or decrease of the returned frequency or Doppler shift, is directly proportional to flow velocity. This signal is mixed with the transmit signal and modulates much like an AM radio signal. The receiver demodulates (removes) the high frequency signal to recover the difference between the transmit and reflected (shifted) signal. This is accurately processed electronically to produce a flow velocity in feet-per-second. The Flow velocity signal is used for indicating, recording, totalizing and process control.

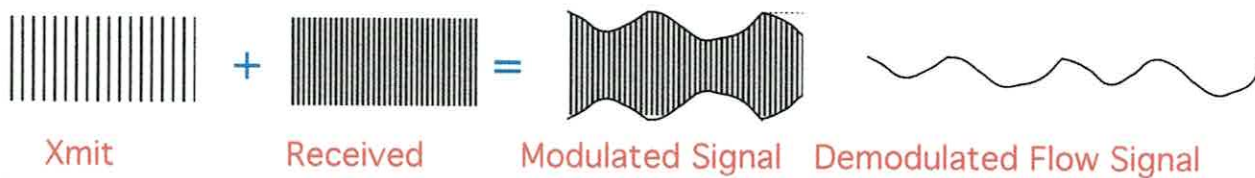

All CPS-460 circuits are protected in a NEMA 4 X, IP65 corrosion resistant fiberglass enclosure with a clear polycarbonate hinged cover for easy viewing of flow indications.

The Sensing element is a non-contacting dual head probe, capable of transmitting and receiving the high frequency sound waves. Installation is easy, requiring no stoppage of flow or intrusion into the pipe. This eliminates costly down time and product contamination.

After installing the flowmeter, the operator will find the CPS-460 Programming Flowchart in the back of this manual extremely helpful in navigating through the many options and features of the flowmeter.

With proper understanding of Doppler technology and successful installation of the flowmeter, the CPS-460 will provide the user with many years of continuous, reliable operation.

INSTALLING THE FLOWMETER

The CPS-460 Flowmetering system is easy to install. Adherence to all installation instructions will result in successful operation of your system. If any deviation must be made from the prescribed installation procedures, please call our service department for change approval. Failure to install your system properly could lead to operational problems and become costly if a service technician is required on-site to remedy. We suggest you read the entire manual to familiarize yourself with the equipment before installing.

1. Controller Installation

The CPS-460 electronics is housed in a NEMA 4X fiberglass enclosure. This enclosure is UL listed and rated as being water-tight, dust-tight and corrosion resistant. However, care should be taken in selecting a location that will offer protection from rain, chemical spills, extreme temperatures etc.

The electronics enclosure is suitable for outdoor installation, but it is recommended that the enclosure be mounted indoors or in a fiberglass shed located next to the measuring site. If the instrument has to be located outdoors, provisions should be made to maintain a temperature range between 25°F and 120°F within the enclosure. For cold locations, our optional Heater and Thermostat should be considered. This option can be installed at any time by the user. In warmer climates the enclosure should be mounted away from direct sunlight or a sun shade should be provided.

IMPORTANT

On a hot day, direct sun light could damage the LCD display and raise the internal temperature of the enclosure well above ambient temperature causing malfunction and/or possible damage to the unit. A Sun Shade should be provided.

The CPS-460 Electronics requires a 120/220 VAC power source. Though the flowmeter is designed to minimize external noise interference you should avoid installation in locations near equipment that may be electrically noisy or instruments that generate R.F. (radio frequency) noise such as SCR controlled equipment (i.e. variable speed controllers). You should also maintain at least a 12" separation from additional Doppler meters to prevent any possible crosstalk between units. This will minimize any potential problems.

The enclosure must be located no more than 25 feet from the measuring point. Standard cable length is 25 feet. Longer cable runs up to 50 feet may be ordered or extended in the field using an RG58A/U coaxial cable. Added cable should run in metal conduit. DO NOT run any other cables, including other Doppler meter sensor cables in the same conduit. Maintain at least a 12" spacing between other cables. Our model 460R is recommended for cables lengths 50 to 1000 feet. Interconnect cable is two twisted pair with ground return, Belden #8723 or equal. The 460R connections are shown in back of manual.

Carefully screw mount the enclosure as shown in figure 1. All conduit entrances must be made through the bottom side of the enclosure. Do not enter through the top. This could cause possible water damage from leaks if the enclosure is rained on or hosed down. Separate conduits should be provided for AC power source (conduit not required if supplied with optional AC power cord) and output signal wires (4-20 mA., relay outputs etc.).

Protect the electronics circuit card from damage when punching holes in the enclosure for conduit entrance. The circuit card may be removed from the enclosure by removing the four retaining screws (along the top and bottom edge of circuit board) and unplugging the ribbon cable. A GREENLEE punch is recommended for punching the holes..

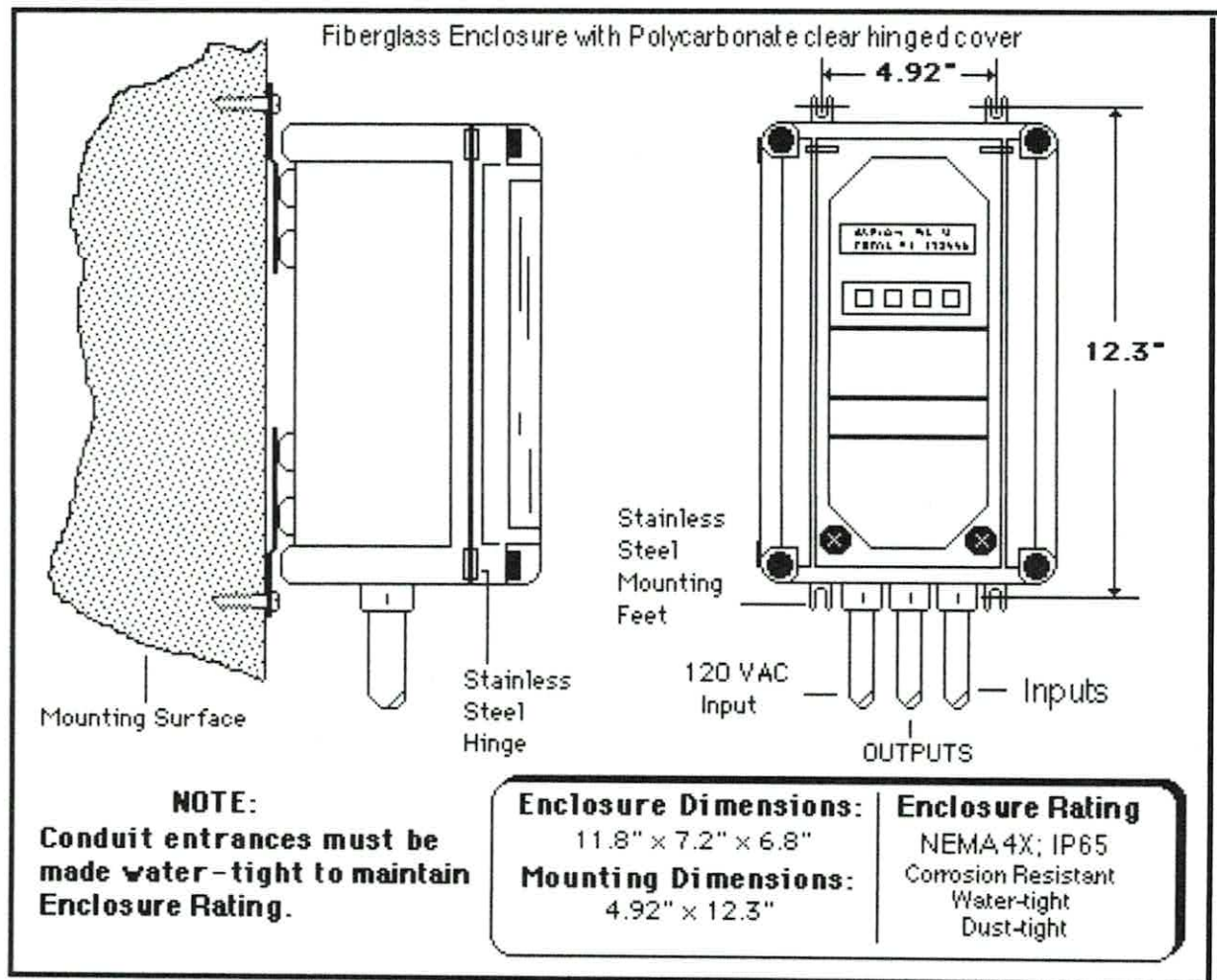

Figure 1.

Enclosure Installation Notes

- 1] Mount the enclosure in a suitable location as described above. DO NOT locate in a confined or hard to reach area.
- 2] All conduit/wire entrances must be made at bottom of enclosure.
- 3] Conduit/wire entrances must be watertight to maintain enclosure rating. Use electricians putty or caulking to plug conduit entrances to prevent condensation and vapor migration.
- 4] Do Not mount enclosure in direct sun light. This could overheat the unit on hot days. A sun shade should be considered.

2. Sensor Installation

Correct Sensor location and mounting is very important for proper operation of your Flowmeter system. The Sensor should be located at least 10 pipe diameters downstream from elbows, tees etc., 15 pipe diameters from a fully opened valve and 25 pipe diameters from partially opened valves. 5 pipe diameters of straight pipe upstream should be available. If proper pipe diameters are not available, calibration inaccuracies may arise and an in-field calibration correction factor will be necessary in the 460's programming.

Potential noise sources such as excessive mechanical vibration and hard to reach areas should be avoided. Lined pipe (i.e.: concrete lined) or old cast iron pipe may be problems. Concrete and clay pipes are not acceptable, though most homogeneous pipe materials such as PVC and steel are good. Insertion of a spool piece may be required if your application cannot provide suitable pipe. Vertical risers from a pump are generally very good locations. On horizontal pipe you should avoid long runs from the pumping source. Gravity pulls downward on the flow in the pipe and long horizontal runs may distort the flow profile affecting calibration and performance.

Refer to APPLICATION GUIDE in back of manual or call our service department.

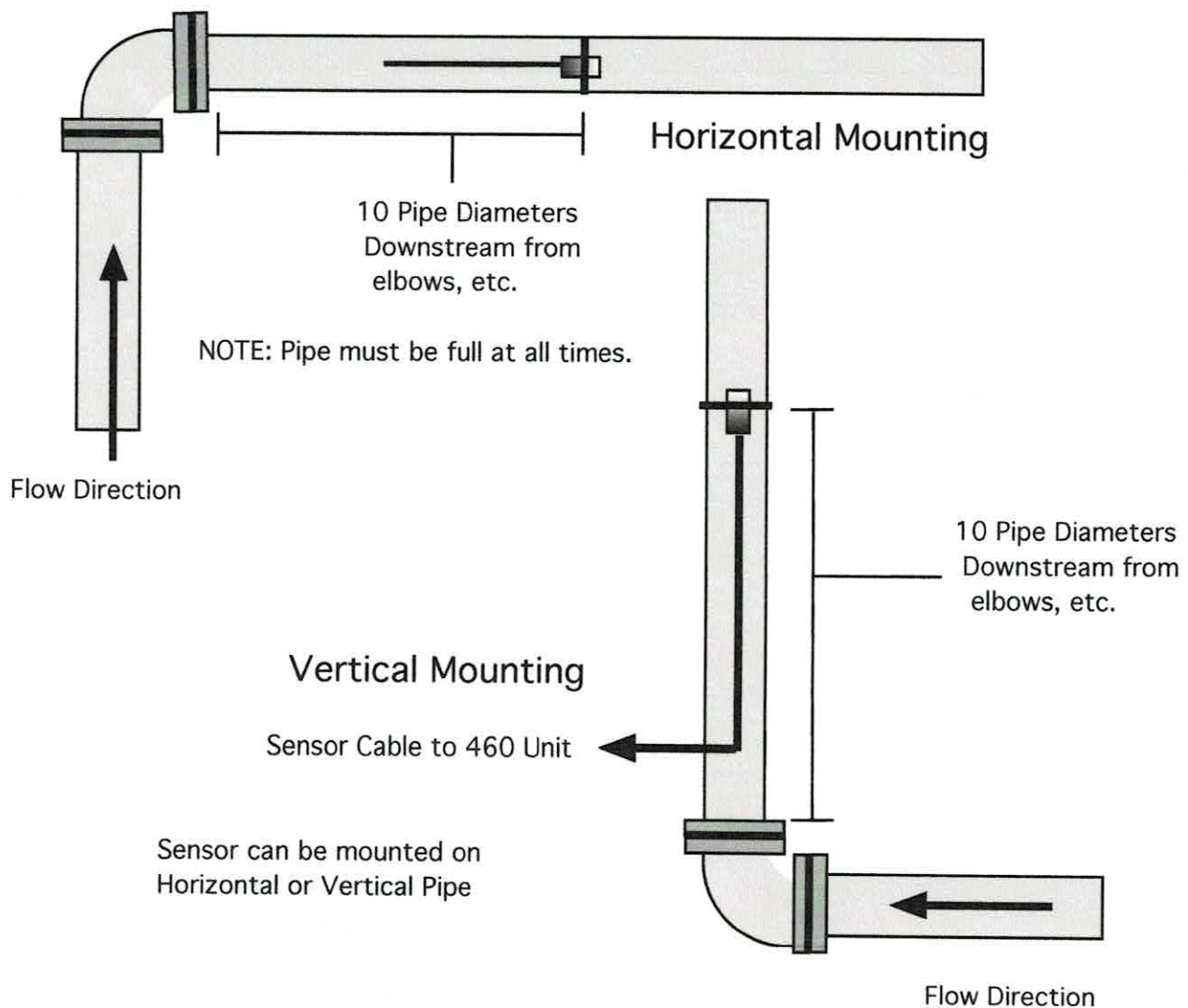

Once a location has been selected, clean thoroughly an area slightly larger than the Sensor head on the pipe, removing all paint, rust, grease etc. On metal pipe, clean down to bare metal. The area selected should be approximately 2 to 4 o'clock or 8 to 10 o'clock on a horizontal pipe. It is necessary that the Sensors be mounted and oriented properly on the pipe as illustrated in figure 2.

IMPORTANT

DO NOT mount the Sensor on top or bottom of the pipe.
This will seriously degrade the performance of the flowmeter.

Mount the Sensor by first applying a generous amount of couplant paste (supplied - silicone grease) to the Sensor's epoxy surface. Be sure the entire surface is covered. Using a hose clamp or duct tape, fasten the Sensor snugly (do not over-tighten) to the pipe making sure the Sensor's cable is running parallel to the pipe axis. Liquid flow may be in either direction but typically the sensor cable points in the direction of the flow source. Remember, most problems with the flowmeters performance can be traced to poor Sensor location and/or mounting.

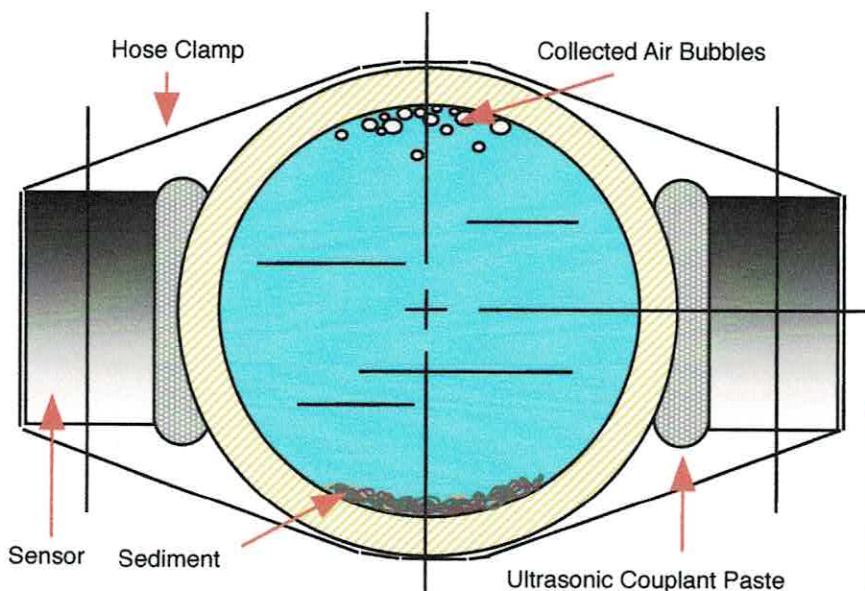
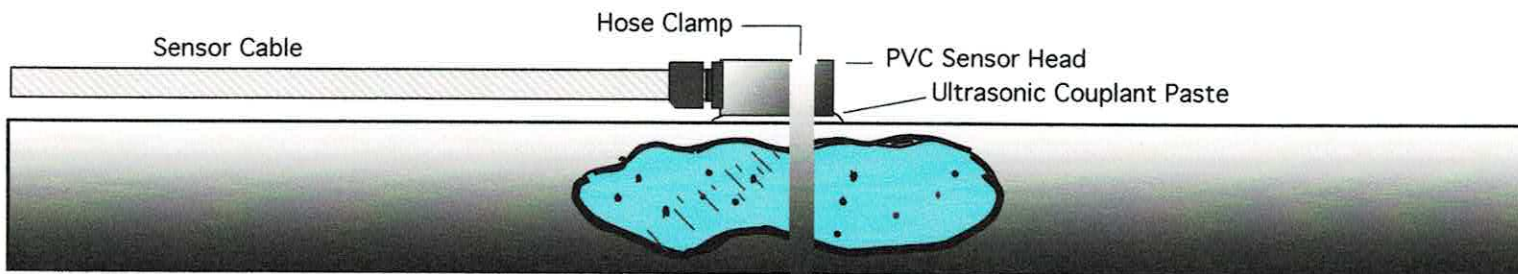

Sensor Mounting:

1. Do not mount sensor on top or bottom of horizontal pipe.
2. Clean pipe thoroughly where Sensor is to be mounted.
3. Cover entire sensor surface with a thick layer (1/4") of ultrasonic couplant paste.
4. Secure sensor to pipe with hose clamp or other means. (do not over tighten).

DUAL HEAD MOUNTING

Mount Sensors as shown on pipes of 20" or less diameter. For larger pipes, mount sensors at 2 and 3 o'clock position on pipe.

Note: Silicone Grease (supplied) is used as Ultrasonic Couplant paste.

Figure 2.

The Sensor is provided with at least 25 feet of cable (standard), maximum is 50 feet. Make sure the sensor location selected is in reach of the controller.

CPS-460R

If longer cable or separation of sensor to controller is needed, our optional 460R system should be purchased. The sensor cable will connect to the 460R Remote Doppler Card in a NEMA 4X enclosure and a two twisted pair cable with ground return will connect the Doppler card to the controller using Belden# 8723 or equal interconnect cable. Up to 600 feet of interconnect cable may be used. The 460R connections are shown in back of manual.

Sensor Installation Notes

- 1] Determine Sensor location on pipe as described above.
- 2] Make sure sensor cable will reach the controller.
- 3] Mount the Sensor using the supplied couplant (silicone grease). Use a hose clamp or duct tape to secure the sensor to the pipe. DO NOT over tighten the clamp. Refer to figure 2.
- 4] DO NOT mount the sensors on top or bottom of a horizontal pipe.
- 5] When running the Sensor's cable, you must avoid close proximity to AC power lines and other frequency carrying lines. **Variable Speed Drives for pumps can create a lot of problems for Doppler flowmeters and should be avoided.**
- 6] Pull Sensor cable through conduit if used being careful not to nick or puncture the cables outer insulation.
- 7] Seal and tighten any junction box lids and conduit connections to prevent water infiltration.

3. Electrical Connections

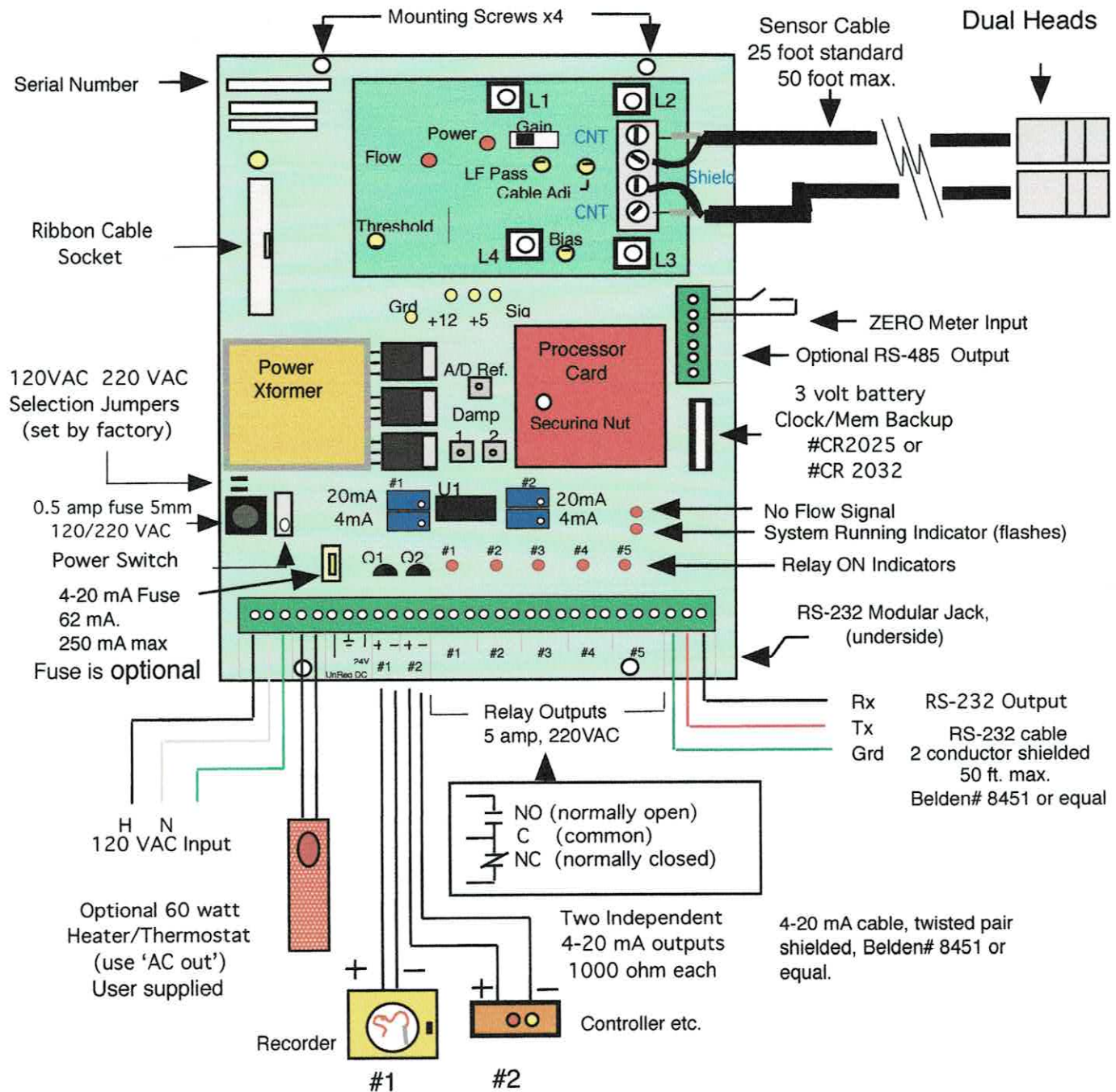

CPS-460 Wiring Interconnect Diagram

Note: Relays and RS-232 Output are not available on the CPS-460DX
CPS-460R Wiring Diagram in back of manual

Figure 3.

SENSOR CABLE

The Sensor cables must enter through the bottom side of the enclosure. Be certain to make a good water tight entrance with the cable to maintain the enclosure NEMA 4X rating. If the cable is ran in conduit, plug the conduit with electricians putty or caulking to prevent moisture/gas migration.

Connect the Sensors cables to the four (4) pin terminal barrier strip at the top right of the electronics card in the enclosure, see figure 3 above. The coax shield to SHIELD and the centers to CNT as shown. The two cables are identical and interchangeable. Either can be used as the XMITer or RECeiver.

POWER CONNECTIONS

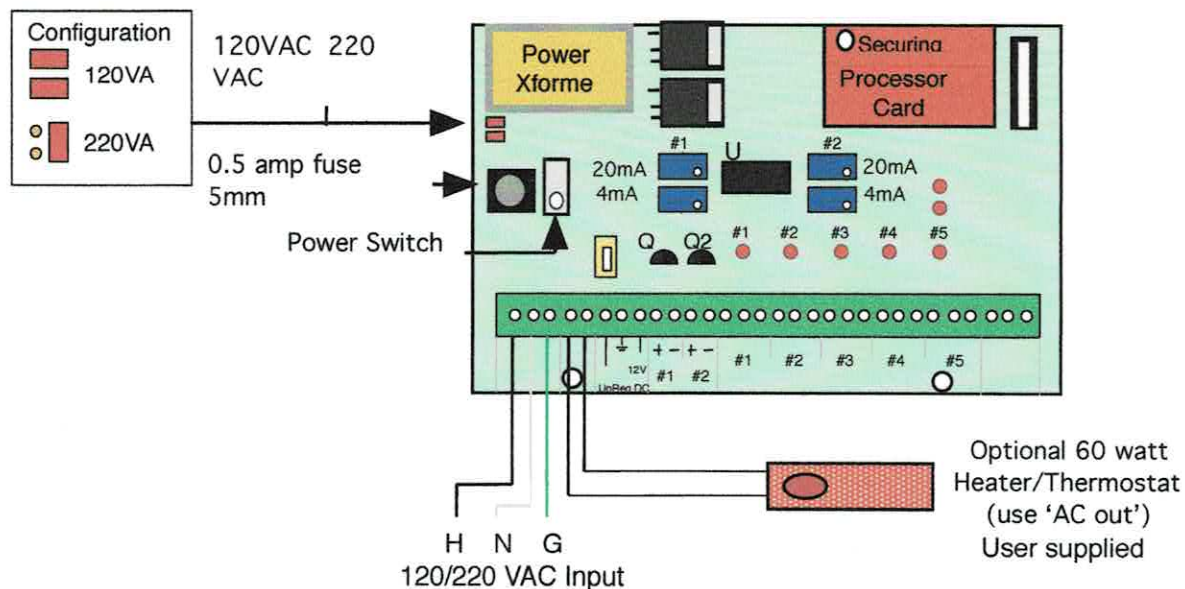

120/220 VAC INPUT

120 VAC power (220 VAC Selectable) **MUST** enter through the bottom side of the enclosure in its own committed conduit (not required if supplied with optional AC power cord). Connect AC power to the terminal barrier strip marked AC INPUT. DO NOT allow the AC wires to lay all about in the enclosure. Keep as short as possible to avoid AC interference. 14 gauge wire is preferred over a heavier wire that may put unnecessary stress on the terminal barrier strip. Fuse power line if needed so as not to exceed wire capacity. The flowmeter has an on board 0.5 amp fuse (1amp with user supplied 60 watt heater).

AC OUT / HEATER-THERMOSTAT

Provides AC power to control an external recorder or optional 60 watt Heater/Thermostat (user supplied) that operate in conjunction with the flowmeter. Power is applied by ON/OFF switch.

NOTE: The flowmeter has a .5 amp 5mm fuse, 1 amp with heater. It may be necessary to increase the fuse rating to accomodate external devices. Max rating should not exceed 3 amps.

UNREG DC, ⏏ (ground) , 12 VDC (Bat), 24 VDC

These inputs/outputs provide DC power for optional accessories or allow for battery operation of the flowmeter. UNREG DC is both an input and an output. When AC power is applied, an unregulated voltage of approximately 16~18 VDC will be found at this point between UNREG DC and GROUND (⏏) and 12 VDC between 12VDC and GROUND.

24 VDC is available between '+' of the 4-20mA output and ground (⏏). This may be used to power customer options. Max current draw should not exceed 150 mA. The 4-20 mA fuse (optional) should be increased to 250 mA or 1/4 amp. when using 24 VDC for external options.

BATTERY OPERATION

BATTERY ONLY OPERATION

If the flowmeter is going to operate from a battery only (no AC power), a standard 12 volt gel cell battery may be connected between 12VDC and Ground on the terminal barrier. The plus '+' of battery to 12VDC and the negative '-' to GROUND (⊕). A 6 amp hour battery is recommended. Max run time approx. 24 Hr.

BATTERY BACK-UP OPERATION

If battery back-up is desired to maintain operation of the flowmeter in the event of a power failure, you may connect a standard 12 volt gel cell battery of at least 1 amp hour or greater at the 12VDC (Bat) connection (plus '+') and ground (⊕) (negative '-') on the terminal barrier. The flowmeter will maintain a charge to the battery when AC power is applied. NOTE: battery back-up is not required to retain the programming. **It is recommended you use a UPS backup device for battery backup protection.**

IMPORTANT

The power switch on the circuit board does not switch the battery supply nor does the fuse offer any protection. Power is applied as soon as the battery is connected to the terminal barrier. We recommend you install a switch and an in-line 3 amp fuse for protection if no on-board fuse is provided for battery.

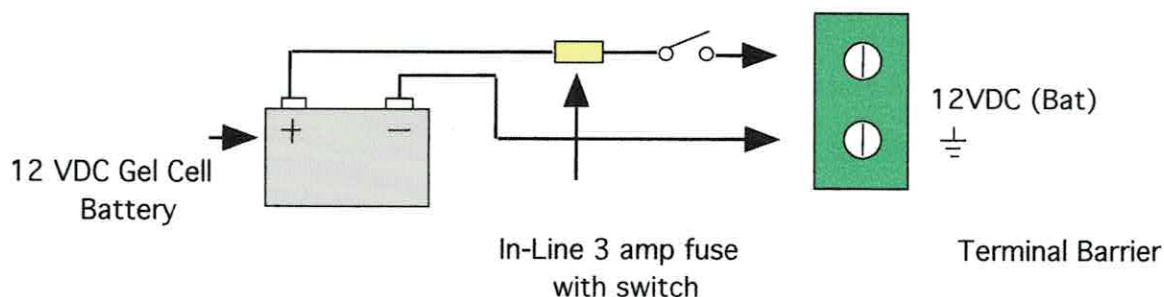

Note: If using 12VDC operation, you must connect '+' lead of 4-20 mA loop to 12VDC.

RELAY OUTPUTS

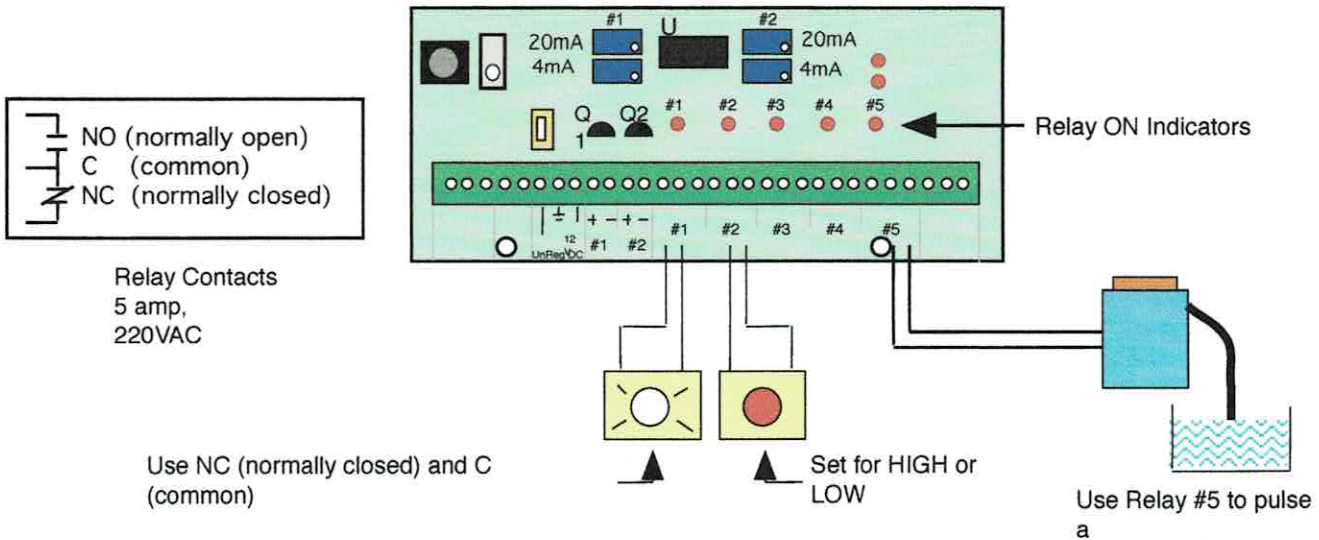

Note: 460DX system does not have Relay outputs

RELAY #1, 2, 3 and 4 outputs (N/A On 460DX)

Relay #1 thru #4 are independently programmable alarm set points used for alarming and control. Both the ON and OFF settings are programmable allowing for pump UP or DOWN control, valve control etc. They are 5 amp, 220 VAC contacts with associated LED status indicators on circuit board. Use wire suitable for electrical load to be carried by contacts. Fuse line if needed so as not to exceed contact rating.

RELAY #5 output (Programmable Pulse, Sampler ... N/A On 460DX)

Relay #5 is a programmable pulse output used for pulsing a remote totalizer counter or for Sampler control. The output is a dry contact rated at 5 amp, 220 VAC. Closure duration when programmed count is met is 250ms. (milli-seconds). After count is reached, the counter will reset for next sample/pulse automatically.

ZERO METER input

A dry contact closure across ZERO METER input will force the Flowmeter to go to ZERO flow indication i.e. GPM = 0.0 and stop totalizer counting. Note: this does not affect the VELOCITY display. Use this input in noisy environments where the Flowmeter continues to indicate some flow when flow has actually stopped. A spare relay contact closure representing a NO FLOW condition, i.e. relay closure opens when there is flow, closes when flow (pumping) stops.

4-20 mA OUTPUTS

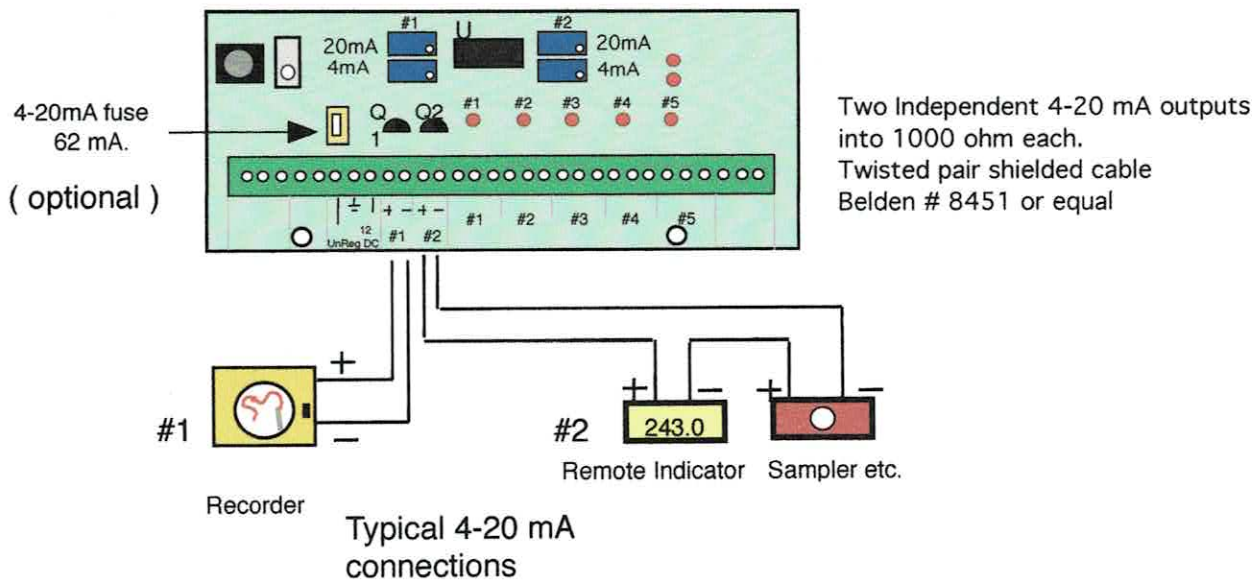

There are two independent 4-20mA. outputs, individually adjustable. They are used to control samplers, set point controls, recorders, chlorinators etc. The two analog output signals are FLOATING outputs (both the '+' and '-' terminals have their potential above system ground) and are DC isolated from electrical ground. The signal outputs are connected as shown. Polarity must be observed through the entire control loop for proper operation. Maximum loop resistance for each output is 1000 ohms. Twisted pair shielded wire should be used, Belden #8451 or equal. Ground wire (bare wire) may be connected to ground (⊕) on the terminal barrier or remote device. Make connection only at one end.

- Notes:
- 1] If 12VDC battery operation is used, you must connect the '+' lead of the 4-20 mA loop to '+' 12V. Max loop resistance will be reduced to 500 ohm.
 - 3] Output #1 will be in GPM (gallons/ minute).
Output #2 will be in Velocity Feet per Second.
These may be scaled in the programming.

REPLACING THE CLOCK / MEMORY BATTERY

This battery is for retaining programmed information and keeping the clock running when power is turned OFF. The battery should last for approximately 8 to 10 years under normal operation. You may replace the battery when power is 'ON' by pulling the battery out of its holder and replacing it with a '#CR2025' or 'CR2032' 3 volt lithium coin battery or equal.

WARNING!!

If the battery is removed when power is 'OFF', all programming and clock / date will be lost. You will need to restart the system as described in the Programming Flowchart in this manual by using the 'SELECT' button to RESET the meter to defaults and then reprogram.

WARNING!

Install Battery Observing Correct Polarity. Install with power applied to the meter.

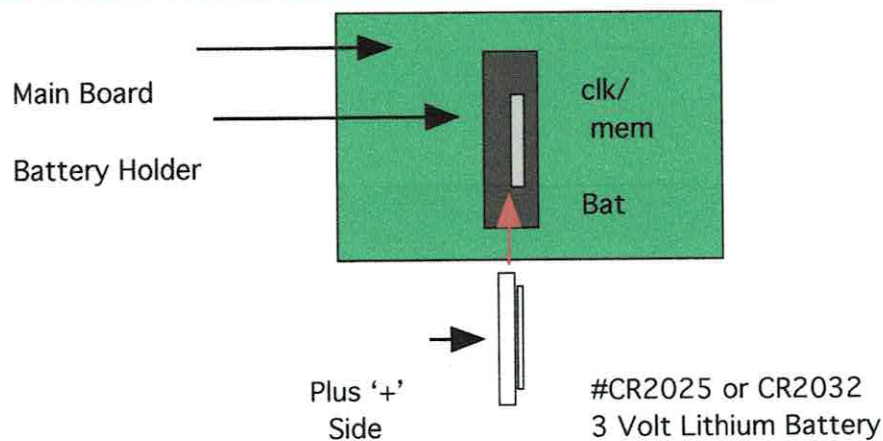

4. ADJUSTMENTS AND CONTROLS

Please note: The following adjustments/calibrations are factory set and should not be touched unless authorized by service technician from Control electronics.

Ultrasonic Transmitter / Receiver Card

Tuning Coils

- L1 Coil Sets the transmit frequency. Approximately 640KHz. Factory Set.
- L2 Coil Couples the Transmitter to the transmit Sensor. Factory Set.
- L3 Coil Couples the receive Sensor to Receiver circuit. Field Adjustable.
- L4 Coil Tunes the Receiver to the Transmit frequency. Factory Set.

PreGain

Sets the GAIN of the high frequency receiver. Factory Set.

Threshold

Sets the threshold level for the Doppler Signal. Increase CW slowly if FLOW SIG LED flickers when there is no flow. Note: too far CW may cause loss of signal.

Flow Signal LED

This LED lights when there is a flow signal. Intermittent flashing indicates poor signal return. The LED should be OFF when there is no flow.

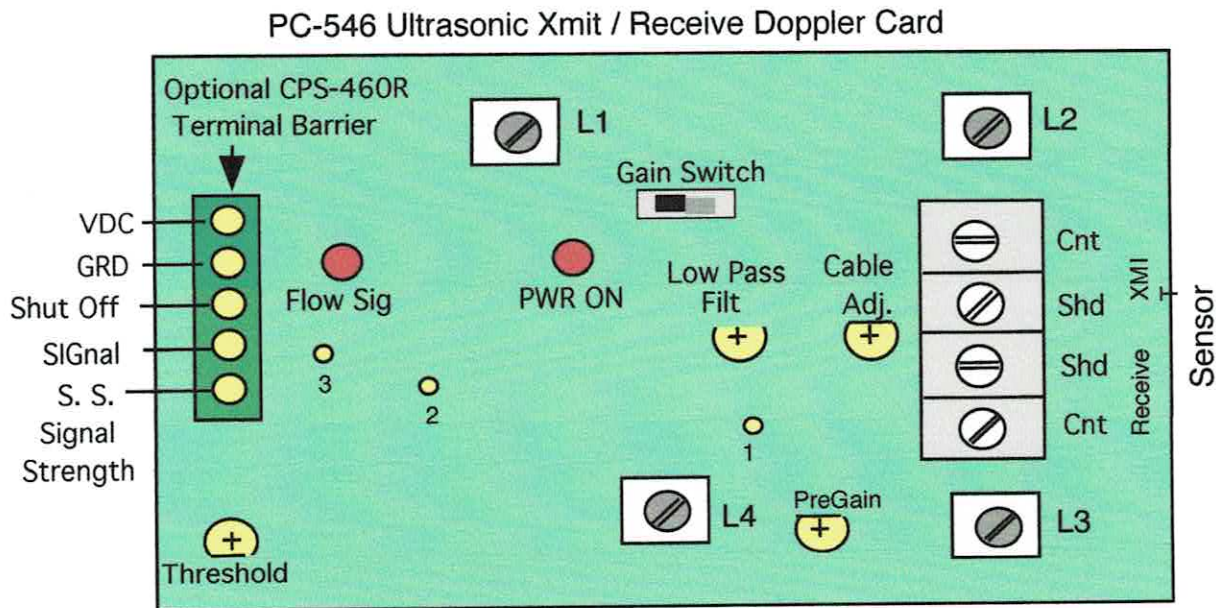

Adjustments shown in their NORMAL position

Figure 4.

Low Pass Filter Adjustment

This adjustment may be used in conjunction with the THRESHOLD adjustment to reduce problems in noisy applications. Turn CW to increase filtering. NOTE: too much filtering may cause loss of higher flow velocities signals.

Cable Adj.

If you increase cable length (max 50 feet) you may need to increase this adjustment to compensate. Also, on pipes larger than 8 inches with dual-head sensors, it may be necessary to increase to maintain good signal strength.

GAIN switch

Slide switch to ON position. When the flow velocity drops below the LOW FLOW SHUT OFF setting programmed by the user, the system will reduce the GAIN of the receiver to reduce unwanted noise during no-flow conditions. Slide switch to 'right' to defeat this function.

Main Circuit Board

Refer to Figure 3, page 7, for the following adjustments.

ON/OFF Switch

Applies AC power to the circuit board and AC out to the AC OUT on the terminal barrier.
Note: this switch does not control battery power if connected.

120/220 VAC

Install or remove appropriate jumper(s) to change operating voltage to 120 or 220 VAC operation.
Note: this is factory set. Jumpers are located under left-bottom corner of power transformer.

4 and 20 mA

The 4 and 20 mA adjustments are used to set the 4-20 mA output. See SETTING THE 4-20 MA OUTPUTS.
Note: 4-20 mA adjustments have been factory set and should not require any adjustment.

LED's 1 thru 5 (N/A CPS-460DX)

These LED lights will lite when associated relay is energized. LED 1 thru 4 represent setpoints. LED 5 represents the programmable pulse to a sampler or remote counter.

RUNNING LED

Each time the system makes a flow measurement, this LED will flash. Typical rate is 4 times per second. This is considered normal operation and should be flashing steadily.
Note: when downloading data log this LED will appear erratic.

NO SIGNAL LED

This LED will lite when there is no flow in the pipe. i.e. OFF when flow is sensed, ON when no flow.

CLK/MEM 3V Bat

This battery retains programming and keeps the clock running when power is turned OFF. You may replace the battery when power is 'ON' by pulling the battery out of its holder and replacing it with a '#CR2025', '#CR2032' or equal. Battery life is approximately 8 to 10 years.

STARTING UP THE FLOWMETER

Once all installation procedures have been completed, the CPS-460 Flowmeter is ready to be powered up. But before doing so, it is advisable that you go back and check your installation.

Before Applying Power Quick Check List

- 1] confirm that all wire connections are correct and secure, particularly the AC power input with correct circuit breaker size.
- 2] confirm that the sensor has been installed properly and all gaps between the sensor face and pipe wall have been filled with couplant paste (Silicone Grease).
- 3] make sure all conduit entrances to the enclosure are watertight. Use electricians putty or caulking to plug conduits to prevent condensation and gases migrating to enclosure.
- 4] know the pipes inside diameter (ID) in inches. You will need this to program the flowmeter.

You are now ready to power up the flowmeter.

TURNING POWER ON

Turn AC power Circuit Breaker ON back at the electrical panel if needed. Switch the POWER ON to the flowmeter by switching the small toggle switch on the lower left of the main circuit board to ON.

Once power is applied, the flowmeter will power up and display a few banners indicating manufacturer, Model Number and software revision number. Before shipping, the flowmeter was set to factory defaults and should now display VELOCITY and GPM flow rate.

Please note: The values displayed will most likely be incorrect, showing 0.0 values if there is no flow in the pipe. This is normal. The flowmeter has not yet been set up to your application.

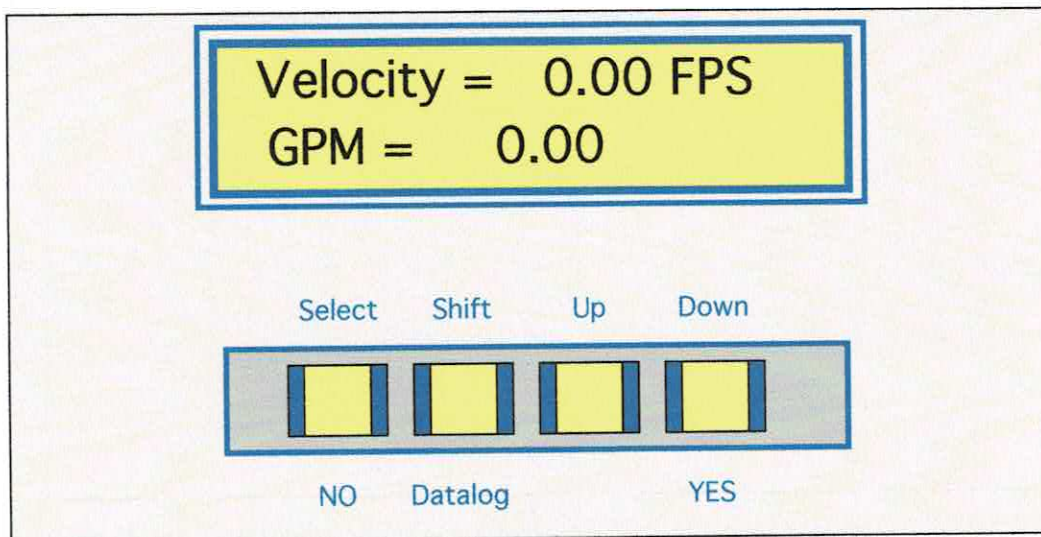

INITIAL RUN MODE DISPLAY AND KEYPAD LAYOUT

Wait approximately 15 seconds before doing any programming.

The Flowmeter is now operating. The 'RUNNING' LED light on the main circuit board should be flashing (approx. 4 times per second) and the 'NO SIGNAL' LED should be 'ON' if there is NO FLOW in the pipe or 'OFF' if there is flow. Some relays may energize, depending on the default settings.

NOTE: If there is flow in the pipe and the 'NO SIGNAL' light is 'ON' or there is NO FLOW, but the flowmeter is indicating flow, you may need to refer to the TROUBLESHOOTING GUIDE in the back of the manual after programming.

PROGRAMMING THE FLOWMETER

You can now begin programming the flowmeter once the STARTUP procedure above has been completed successfully. The keypad on the front panel is used for selecting the various RUN MODE indications and PROGRAMMING MODES of the flowmeter.

- 1] Use the SELECT button to scroll through the program selections, selecting NO/YES where needed.
- 2] To change any value, use the SHIFT button. This moves the cursor ('_') under the digit you want to change.
- 3] Use the UP and DOWN buttons to change the value of the selected digit.

When in the RUN MODE, press the UP or DOWN button to display the RUN MODE parameter you desire. The 4-20 mA. output is not affected by the selection of any RUN MODE window.

RUN MODE Selections with metric equivalents:

GPM or MGD .. TOTAL in Gallons (LPM or Cm/h ... Total in Liters)

Flow may be displayed in GPM (gallons per minute) or in MGD (million gallons per day) units with TOTALIZER count. The TOTALIZER is an 8 digit counter that indicates the total accumulated flow in gallons to date. The total will be equal to the count displayed times the multiplier (i.e. x100) indicated. The multiplier may be programmed under the SET FLOW PARAMETERS section.

VELOCITY FPS .. GPM (m/s and LPM or Cm/h)

VELOCITY indicates the measured Feet/Second (FPS) of liquid as it passes through the pipe. This reading is used in the equation for the selected pipe size ID to calculate the GPM flow rate reading and finally a total accumulated flow.

$$\begin{aligned} \text{GPM} &= \text{ID inches squared} \times \text{FPS} \times 2.45 \\ (\text{LPM}) &= \text{ID mm squared} \times \text{m/s} \times .04712 \end{aligned}$$

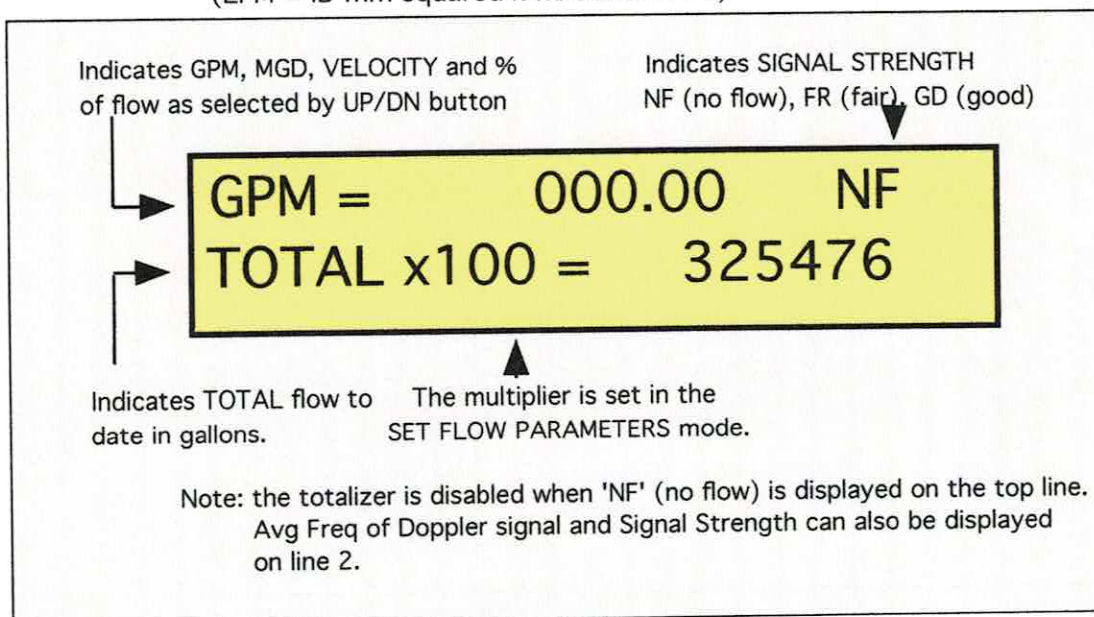

TYPICAL RUN DISPLAY

Measured Frequency

This is the average measured demodulated Doppler frequency. The frequency is directly related to flow velocity. This value is divided by the Set Sensor Cal/Fact under the Misc Settings... in the programming to calculate VELOCITY in Feet/Second. 70 Hz = 1 FPS is the default and should not be changed.

$$\text{Velocity in FPS} = \text{Measured Frequency} \div \text{Sensor Cal/Fact}$$

Flow % .. Signal Strength

FLOW % indicates the percent of flow as found on the 4-20 mA. output #1. The output is scaled by the SCALE 20 mA. OUTPUT #1 under the SET FLOW PARAMETERS mode in programming.

The Doppler Signals Signal Strength is indicated as a percent. It is best to maintain a signal strength of at least 30%. The flowmeter will respond to lower values but may not be as accurate.

NOTE: low flow velocities (less than approximately 2.0 FPS) inherently have low signal strength. It would not be unusual for signal strength to drop to lower values during low flow velocities. This is normal.

NF (No Flow).....

The letters NF displayed in the top right corner of the display (GPM and MGD modes only), indicate that the LOW-FLOW SHUT-OFF is activated and/or the system senses no flow in the pipe. When the flow velocity calculated by the flowmeter is below the LOW FLOW SHUT OFF FPS setting programmed by the operator, the %, GPM, MGD readings and analog output #1 (i.e. 4-20mA) will be forced to zero. The totalizer also stops counting at this time. The VELOCITY display will not be affected.

FR (fair), GD (good)

The letters FR or GD displayed in the top right corner of the display (GPM and MGD modes only) indicate the relative Signal Strength. It is best the flowmeter maintains GD (good) signal strength. FR (fair) will be displayed when signal strength drops below 40%. Note: low flow velocities, 2.0 fps or less, may show FR (fair) signal strength. This is not unusual. Low velocities inherently have low signal strength.

BEGIN PROGRAMMING

The programming of the flowmeter is accomplished by first pressing the SELECT button. You will be asked if you want to GO TO PROGRAM MODE? If you select YES you will be asked to ENTER YOUR PASS CODE. Enter the PASS CODE using the SHIFT , UP and DOWN buttons . If the wrong PASS CODE is entered, the display will return to the RUN MODE last selected.

Note: The flowmeter leaves the factory with pass code '0000'

Press the SELECT button again. You are now asked CHANGE PASS CODE?. If you like, you may change the pass code at this time by using the SHIFT, UP and DOWN buttons. If you change the pass code

IMPORTANT

Remember your new PASS CODE !!!

If you forget your pass code and can not enter into the programming section, you will need to call the factory at 610-942-3190. Please have your flowmeters serial number available. It is found on the upper left corner of the main circuit board.

Press the SELECT button and you will be asked SET FLOW PARAMETERS. Select YES to enter this section.

Refer to the PROGRAM FLOWCHART in this manual for navigating through all the programming functions.

Enter the Pipe Inside Diameter (ID) in inches using the SHIFT, UP and DOWN buttons. It is important to make this as accurate as possible. All calculations will be referenced to this number. Press SELECT to continue to the other parameters.

SITE CAL FACTOR should be 1.00. Leave this value unless an in-field calibration is required. Example: if flow indications are determined to be 10% high, you would enter a CAL FACTOR of 0.90 to reduce reading by 10%; if readings are 5% low, enter 1.05 to correct the reading. Press SELECT button.

This completes the basic calibration. All other settings are optional.

Continue down the FLOW PARAMETERS list referring to the PROGRAM FLOW CHART #2 in this manual. A brief explanation of each parameter is given in the programming flow chart.

SETTING/TESTING RELAY OUTPUTS

(N/A on 460DX)

TESTING THE RELAY OUTPUTS

The relay outputs can be tested by going to SET RELAY OUTPUTS mode in the programming (refer to flow chart #3), select YES. Select 'YES' at TEST RELAY OUTPUTS?. The display will show

Test Relay #0
Done ON OFF Select

- 1] Use the DOWN button to Select the relay number (1 thru 5).
- 2] Press the SHIFT button to turn the selected relay 'ON'.
- 3] Press the UP button to turn the selected relay 'OFF'.
- 4] Press the SELECT button when 'DONE'.

SET RELAY OUTPUTS .. Relay 1 ~ 4

The CPS-460 has four (4) independently programmed alarm relay outputs. The programming is performed under the SET RELAY OUTPUTS? mode. Each Relay output has a separate ON and OFF setting for differential control of pump ON and pump OFF or valve open/close etc. The program values are in GPM (gallons per minute). The relay contacts are dry contact closures rated 5 amp, 220VAC. An associated LED will light when the relay is energized.

Note: while in the program mode, the relay outputs will not be affected by any program change. Once you are back in the RUN MODE, the new values will take affect.

SAMPLER OUTPUT ... Relay #5

The SAMPLER PULSE output, Relay #5, is used to pulse a remote Sampler or counter. It is programmed under the SET RELAY OUTPUTS? mode ... Relay #5 Sampler Pulse ... 1 Pulse = 000000 gal. Example: if you need to sample your flow every 1000 gallons, you would program the SAMPLER PULSE rate for '001000'. If a remote counter needs to be pulsed, enter a multiplier i.e enter '000100' for x100. A programmed setting of '000000' gallons disables the pulse output.

The relay will close for a duration of 250 ms. (= 1/4 sec) when the count is reached. The function will automatically reset itself for the next count. The relay contact is a dry contact rated 5 amp, 220 VAC. An associated LED will flash when the Sample is made.

After setting the SAMPLER output, you may choose to log the time and date each sample is taken by selecting 'YES' or 'NO' when asked LOG SAMPLER EVENT?

When a relay switches state (i.e. OFF to ON, ON to OFF), the relay number, time and date will be logged in the EVENT LIST. The EVENT LIST can be viewed by downloading the data to a PC/Lap Top through the RS-232 output. See using the RS-232 Output.

SETTING COMMUNICATIONS / DATA LOG

Set the RS-232 output parameters and DATA LOG sample rate and 24 hour Summary start time by selecting 'YES' at SET COMMUNICATIONS (see program flow chart #4).

BAUD RATE

Set the BAUD RATE to desired setting by pressing the UP or DOWN button. Rates are 2400, 9600 or 19200. Make sure the selection matches the device connected to the RS-232 output.

DESTINATION

Set SEND DATA TO... PRINTER, PC/LAP TOP, MODEM 1 (LUCENT) or MODEM 2 (CONEX) by pressing the UP or DOWN button. This is only necessary if using an external serial printer or modem.

ID NUMBER

Set the flowmeters ID# if desired. FT-0000 is default. Use the SHIFT, UP and DOWN buttons to set.

COM ADDRESS

Set COM (communication) ADDRESS. The default is 'A'. Select the '#' sign if using a modem. Note: if modem is selected above, the '#' sign will automatically be set. When using a modem, you can change the COM ADDRESS to other value except 'A', 'N' or 'Y'. These are reserved. The COM ADDRESS will be used when downloading data to a PC/Lap Top.

DATA LOG SAMPLE RATE

Sets the SAMPLE RATE for Data Logging. i.e., entering 30 minutes indicates that every 30 minutes the GPM Flow Rate for the past 30 minutes will be averaged, logged and time stamped. If you set to '00' minutes, the data logging will be disabled. The Data can only be viewed by downloading to a PC/Lap Top.

Note: this setting does not affect the 24 hour summary logging.

24 HOUR SUMMARY

Set the time to begin the 24 hour summary data logging. This will log the DATE, Total Pump Cycles for day, average GPM flow rate for day and Total Gallons Pumped for each 24 hour period over the past 6 months.

This data may be printed to a serial printer on demand or automatically at end of 24 hour period. The data is best viewed by downloading to a PC/Lap Top.

SETTING/TESTING ... 4-20mA OUTPUTS

TESTING

There are two (2) 4-20 mA. outputs on the CPS-460 flowmeter that can be set independently and tested using the TEST 4-20mA OUTPUT? function under SET 4-20 mA.... mode. Enter the TEST 4-20mA OUTPUT by selecting 'YES'. The 4-20mA outputs should go to 4 mA. or 0%. The display will read ...

4-20mA Output = 00%. Done +25 +10 -10
--

- 1] Adjust the '4 mA.' potentiometer adjustment of output #1 and #2 (see figure 3, page 7) for 4 mA. output.
(Note: perform the 4 mA. adjustment first to eliminate any interaction between the 4 and 20 mA. adjustments).
- 2] Press the SHIFT button 4 times to simulate 100% or 20mA.
(Note: Pressing the SHIFT button adds 25% to the output; the UP button adds 10% and the DOWN button minus 10%. By using the SHIFT, UP and DOWN buttons, you can increment and decrement the output in 5% increments).
- 3] Adjust the '20 mA.' potentiometer of each output for 20 mA. output.
- 4] Repeat steps above using the Keypad to simulate an output and confirm the 4-20 mA output.
- 5] Press SELECT (Done) when completed to exit simulate of 4-20mA output.

This completes the testing of the 4-20 mA outputs.

Each of the 4-20mA outputs will drive a 1000 ohm loop resistance.

SCALE THE 4-20 mA

Set the SCALE 20 mA. OUTPUTs #1 and #2 to scale the 4-20mA outputs to a remote recorder or other device if needed. For example, the recorder charts are printed 0-500 (GPM). Set the OUTPUT #1 for 000500.00 GPM. Note: Output#1 is scaled in GPM (gallons/minute).

Output #2 is scaled in Feet Per Second (FPS). Use the SHIFT, UP and DOWN buttons to set.

SET OUTPUT DAMP FACTOR

The DAMP FACTOR controls the response rate of the 4-20 mA outputs. Set the DAMP FACTOR for each of the 4-20 mA outputs by entering a value of 1 to 10 when prompted. 1 being the fastest response, 10 the slowest. A value of 3 is typical.

MISC SETTINGS

FLOW TYPE

Select type of flow condition. Use the UP/DOWN buttons to make selection.

- 1] NORMAL ... for well defined flow profile.
- 2] NON SYMetrical ... for erratic or not well defined flow profiles.

SETTING THE TIME AND DATE (N/A on 460DX)

Set the Time and Date using the SHIFT, UP and DOWN buttons. The Data Logging and 24 hour Summary use the time/date for logging purposes. The time/date is generally set when it leaves the factory but should be checked.

RESET THE TOTALIZER ... DATA LOG

You can RESET the Totalizer to zero and/or RESET (clear) the Data Log (N/A on 460DX) by selecting 'YES' when asked. It is best to do the RESETs when starting up the flowmeter or when the Time/Date have been changed.

Note: The EVENT LIST is not Reset by the Data Log RESET (N/A on 460DX).

SENSOR CAL FACTOR

This is Factory Set and should not be changed unless directed to do so. The flow VELOCITY is calculated using this value. Default = 70 Hz.

$$\text{Velocity (FPS)} = \text{Measured Frequency} \div \text{Sensor Cal/Fact}$$

Changing The Calibration

If it is determined that the flowmeter is incorrect, it may be necessary to do an in-field calibration. The user should first make sure the problem is not due to poor sensor mounting, dried out couplant paste and/or incorrect programming.

Site CAL FACTOR....
Factor = 1.00

Calibration Factor - change value if needed.

If a draw down test is performed or other method of determining flow is done, and the meter is showing 10% high in flow rate, enter a factor of 0.90 in the Site CAL FACTOR ... under SET FLOW PARAMETERS to reduce readings by 10%. if 15% low, enter 1.15 to increase by 15%.

Data Logging (N/A on 460DX)

The CPS-460 Flowmeter continuously logs data as flow measurements are being made. Once memory locations are filled, old data will be written over by new data (auto wrap around). The flowmeter has three (3) independent data log types. They are 1] a 24 hour flow summary; 2] average flow samples and 3] an event list. All data log may be downloaded to a PC/Lap Top for viewing using the RS-232 output (see using the RS-232 output). The 24 hour summary may be directly printed to a serial printer (user supplied) connected to the RS-232 output either on demand or set for AUTO print. The flow totals in gallons for the past 6 months may be viewed at the flowmeter.

24 Hour Summary

The 24 HOUR SUMMARY data log keeps track of each days Total number of pump cycles, Total pump run time, Average GPM flow rates and flow totals for the past 6 months. The START time for the 24 hour summary may be set by the operator under the Set Communications ... Begin 25 Hr. Summary section in the programming. The default setting is 12:00 midnight. The START time begins a new summary page with date and times. To view the 24 Hour Summary you must download the data to a PC/Lap Top computer using the RS-232 output. You will be able to select up to 6 months of data, pre-formatted for quick viewing and print out. (see using the RS-232 output for download instructions).

Viewing Daily Totals

The daily totals can be found in the 24 Hour Summary described above or viewed at the flowmeter by pressing the SHIFT (DataLog) button while in the Run Mode. You will be asked to View Totals? Press YES. The Date and Total gallons for that date will be displayed. (Note: Flowmeter will always begin with todays date. Todays date will show total gallons so far for the day.) Press the UP or DOWN button to select next or previous date; the SHIFT button to go back 1 week at a time or SELECT when finished.

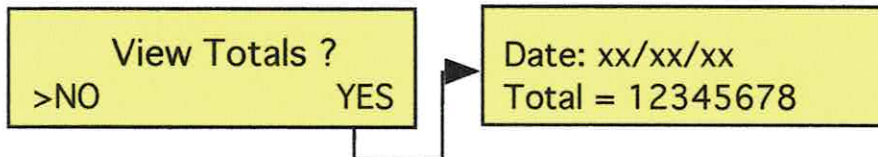

Print Daily Readings (using Serial Printer, user supplied)

If NO is selected in VIEW TOTALS?, you will then be asked Print Daily Readings? If NO, you will return to the Run Mode. If YES, you can select ...

Print NOW. You then will be asked number of days (up to 200). Press Select to begin printing to your serial printer. (Note: the flowmeter sends one data line to the printer and waits approximately 2 seconds for the printer to print before sending the next line. Printing a large number of days may take some time. Approximately 15 seconds per days data).

- OR -

Print AUTO. The flowmeter will display the time the 24 Hour Summary will print each day. (Note: this time is set under Set Communications. Make sure your printer is turned ON). Press the SELECT button to return to the RUN mode.

Average Flow Samples

The flowmeter may be set to log average flow rates in 1 minute increments under Set Communications. You can program the Data Log Sample Rate to sample flow every 1 to 99 minutes in 1 minute increments. If the setting is programmed for 00 minutes, the data log sampling is disabled.

When a sample rate is set, the flowmeter will average the flow rate from the previous log time to the next log time then save and time stamp it.

Example: the flowmeter is set to log data every 30 minutes. The last logged average flow rate was at 10:05 AM. The flowmeter will keep a running flow rate average from 10:05 AM to the next sample time at 10:35 AM at which time it will log the average flow rate and begin the next sample period. The flowmeter does not log instantaneous flow rates which can be misleading.

When the flowmeter goes to ZERO, it will log the next 5 sample periods of ZERO flow then wait for flow to begin again before continuing logging. This is to conserve data log space (i.e. do not want to log large blocks of ZERO flow). The data log will log the start time of the next flow cycle so you will always know when it began and then continue to log at the log sample rate.

This data can be downloaded to a PC/Lap Top using the RS-232. The data will show DATE, TIME and FLOW RATE. You can also select the data to show a bar graph next to itself to see a visual trend.

Event List

The Event List logs the date, time and event type when it happens. Events types are ...

- | | |
|------------------------|-------------------------|
| 1] System Restart | 6] Master Reset/Startup |
| 2] Entered Programming | 7] Reset Totalizer |
| 3] Relay #x ON | 8] Reset Data Log |
| 4] Relay #x OFF | 9] Reset Event List |
| 5] Sampler Pulsed | |

The Events may be viewed by downloading to a PC/Lap Top using the RS-232 output.

Resetting The Data Log

The Data Log may be RESET (clear all data) by selecting YES when asked Reset The Data Log? under Misc Settings. Note: this does not RESET the Event List. This can only be Reset by doing a MASTER RESET to the meter or by downloading the data to a PC/Lap Top and selecting RESET EVENT LIST.

Resetting The Flowmeter

If the SELECT button is held when power is applied to the flowmeter, then released, the user will have access to the flowmeters reset function. The flowmeter will display manufacture, model, type meter and software revision number (Rv).

The user may reset the flowmeter by selecting YES to FACTORY DEFAULTS when prompted then RESET Totalizer / clock. The operator must now proceed to reprogramming the flowmeter.

Note: This reset will set the pass code to '0000'.

The Resets can help recover from a processor crash or lockup due to lightning, surges etc. The user may proceed to resetting the totalizer / clock. Data log may be cleared in the PROGRAMMING section .

If The Flowmeter Should Lockup or Crash

It is possible that the flow of the program may be interrupted by some external event such as lightning, testing back-up generators or some other anomaly on the AC or Sensor input that may cause the flowmeter to crash or lockup. Turning power OFF and waiting approximately 10 seconds before turning the meter back ON may correct/unlock the meter. If not, it may be necessary to perform a RESET using the SELECT button mentioned above, RESETTING THE FLOWMETER. You should only need to do a FACTORY DEFAULT reset and then reprogram the flowmeter. You should not need to reset the totalizer or data log.

In extreme cases, it may be necessary to do a HARD Reset by first turning power OFF to the flowmeter and then removing the 3 volt clock/memory coin battery from its holder for about 1 minute. This will cause a loss of all data, including totals and data logging.

Reinstall the coin battery (note polarity) and do a power up reset using the SELECT button as mentioned above. Proceed to reprogramming the meter. Set the clock and date and RESET the totalizer and data log when asked.

Using The CPS-460 FLOWCHART

OPERATING INSTRUCTIONS

When power is first applied, the PDS-360 flowmeter will run through its POWER-UP windows. It should display 2 windows indicating name of manufacturer, model number, type of meter and the software revision number. The process takes a few seconds and will then enter the RUN MODE. The flowmeter will display the window that was ON (selected) prior to turning power 'OFF'. To select or scroll through the RUN MODES, use the UP/DOWN buttons. Each press of the button takes you to the next window. Selecting any of the RUN MODES will not affect the 4-20 mA. output or any of the programmed settings. The flowmeter begins monitoring flow automatically.

To enter the PROGRAM MODE, press the SELECT button. You will be asked GO TO PROGRAM MODE?. Press YES. You will be asked for the PASS CODE before you can enter into the PROGRAM MODES. The pass code is 0000 when it leaves the factory and will remain this until you change it. Press SELECT. If you like to change the code at this time, use the SHIFT, UP and DOWN buttons to enter your new pass code then press SELECT. This stores your new code. You now have access to the program section. If the wrong pass code is entered, you will be returned to the RUN MODE.

REMEMBER YOUR PASS CODE!!!

Once you entered the PROGRAM MODE you can scroll through it by pressing the SELECT button. The SELECT button performs three functions: 1] NO, 2] ENTER and 3] NEXT WINDOW. Use the SHIFT, UP and DOWN buttons to change the values in each window as needed. The DOWN button is used to select YES when data values are not displayed. The Programming Flowchart will guide you through the many features and functions available to you. A brief explanation for each window is provided in the flowchart.

CPS-460 Program Flowchart #1

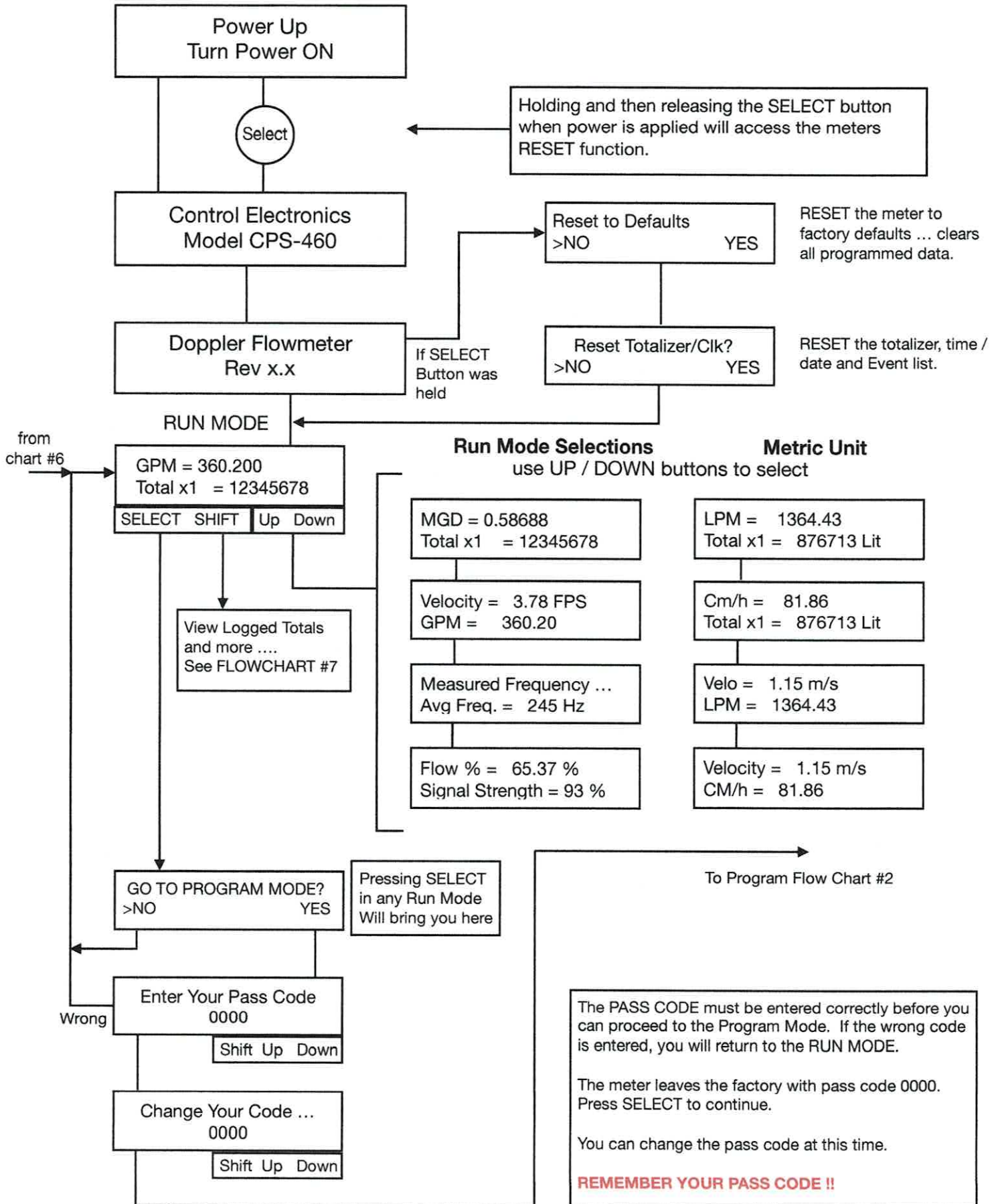

CPS-460 PROGRAM FLOWCHART #2

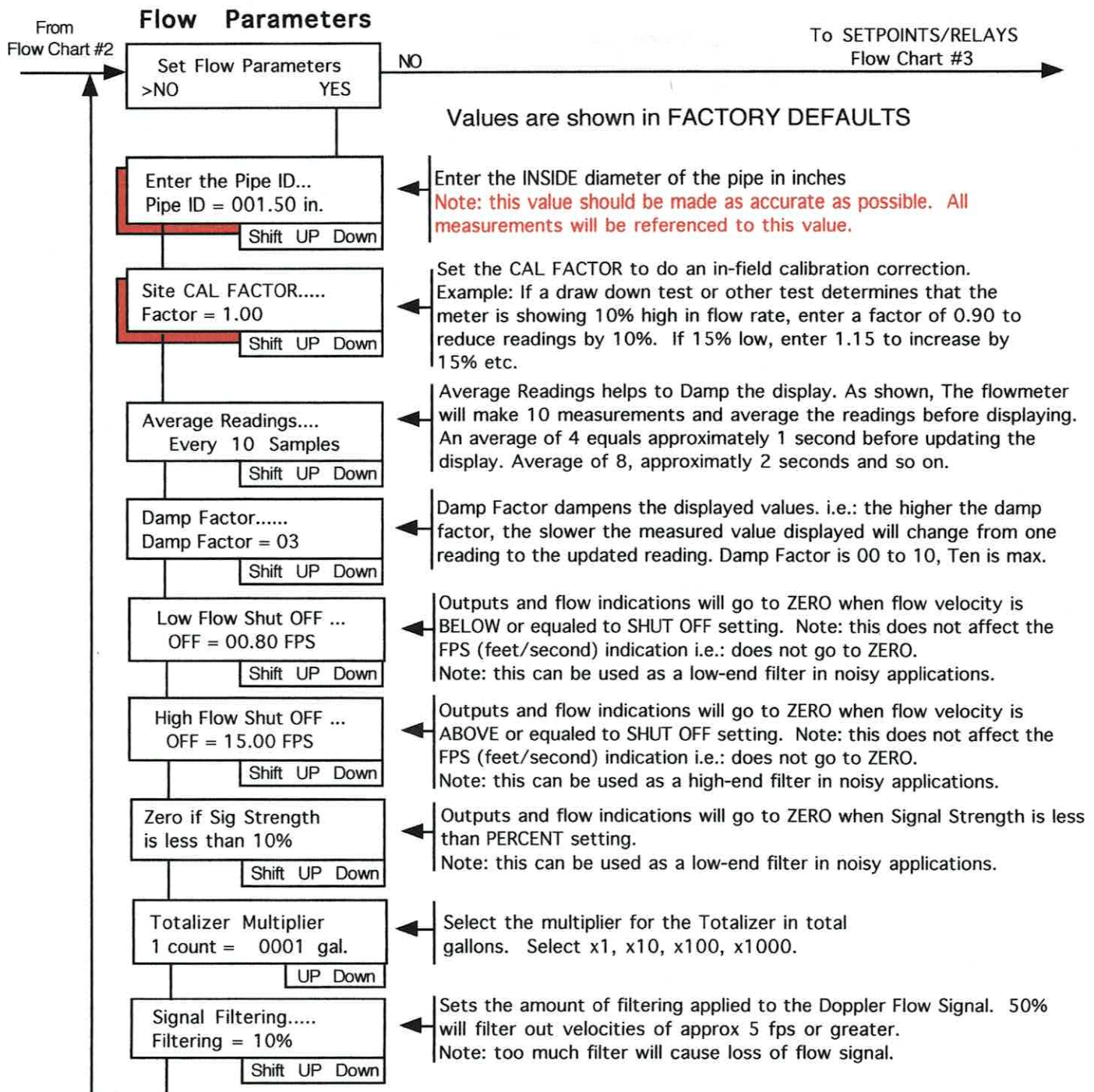

Note:

Shaded Windows indicate that these parameters MUST be set by the operator to calibrate the flowmeter to the application. All other settings are optional to the user.

CPS-460 PROGRAM FLOWCHART #3

RELAY OUTPUTS - N/A on 460DX

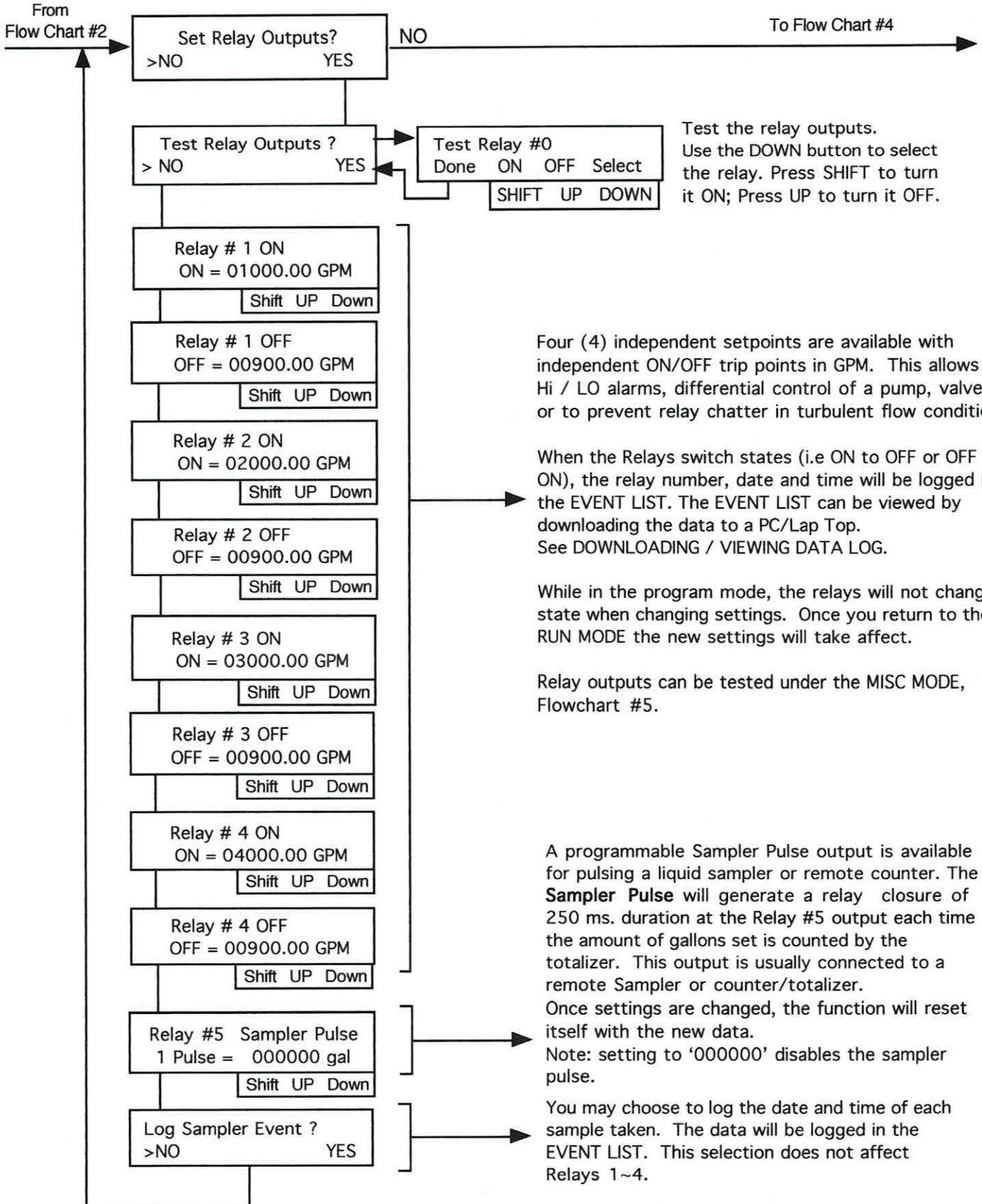

Test the relay outputs. Use the DOWN button to select the relay. Press SHIFT to turn it ON; Press UP to turn it OFF.

Four (4) independent setpoints are available with independent ON/OFF trip points in GPM. This allows for Hi / LO alarms, differential control of a pump, valve etc. or to prevent relay chatter in turbulent flow conditions.

When the Relays switch states (i.e ON to OFF or OFF to ON), the relay number, date and time will be logged in the EVENT LIST. The EVENT LIST can be viewed by downloading the data to a PC/Lap Top. See DOWNLOADING / VIEWING DATA LOG.

While in the program mode, the relays will not change state when changing settings. Once you return to the RUN MODE the new settings will take affect.

Relay outputs can be tested under the MISC MODE, Flowchart #5.

A programmable Sampler Pulse output is available for pulsing a liquid sampler or remote counter. The **Sampler Pulse** will generate a relay closure of 250 ms. duration at the Relay #5 output each time the amount of gallons set is counted by the totalizer. This output is usually connected to a remote Sampler or counter/totalizer.

Once settings are changed, the function will reset itself with the new data. Note: setting to '000000' disables the sampler pulse.

You may choose to log the date and time of each sample taken. The data will be logged in the EVENT LIST. This selection does not affect Relays 1~4.

CPS-460 PROGRAM FLOWCHART #4

COMMUNICATIONS / DATA LOG - N/A on 460DX

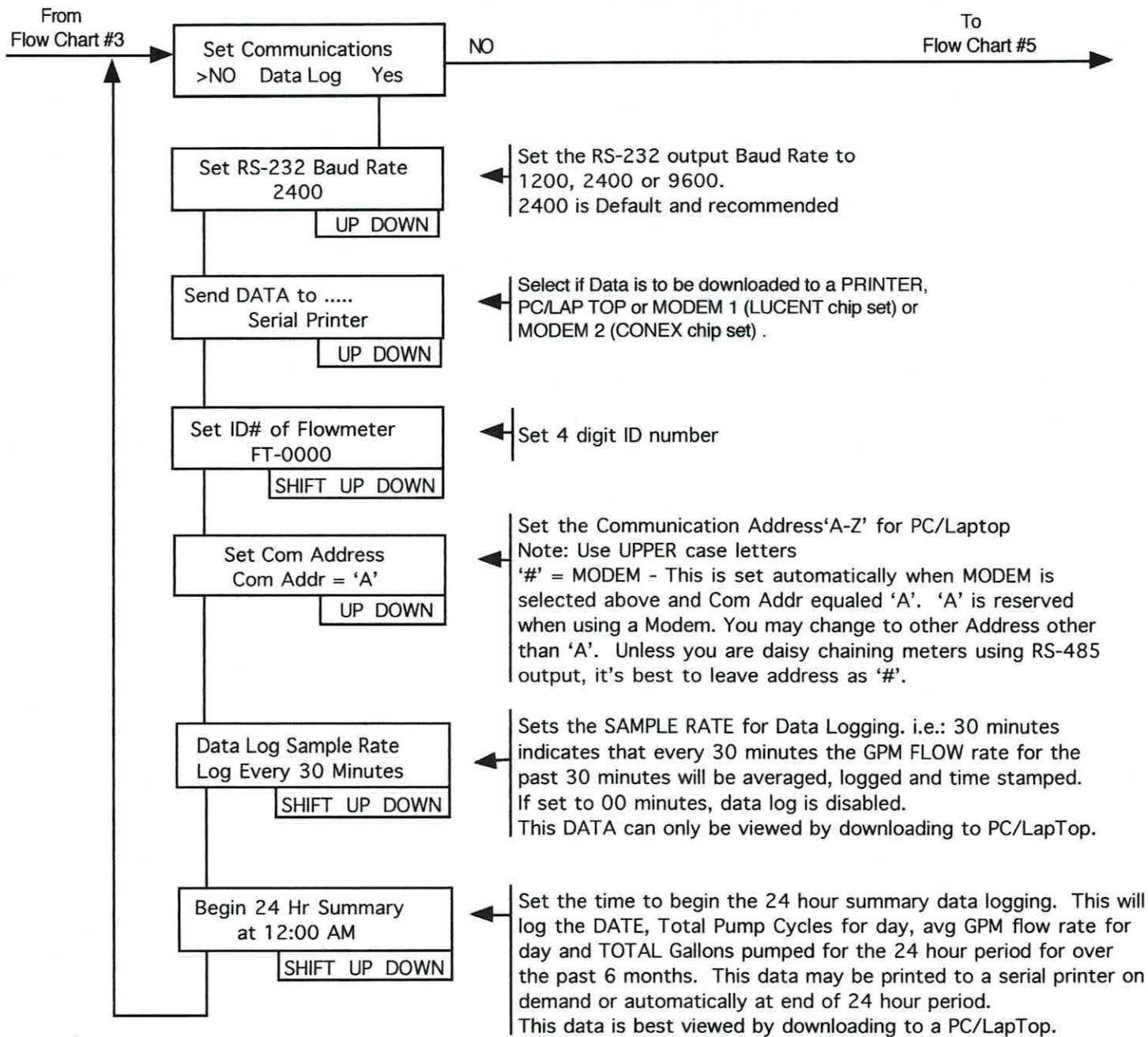

CPS-460 PROGRAM FLOWCHART #5

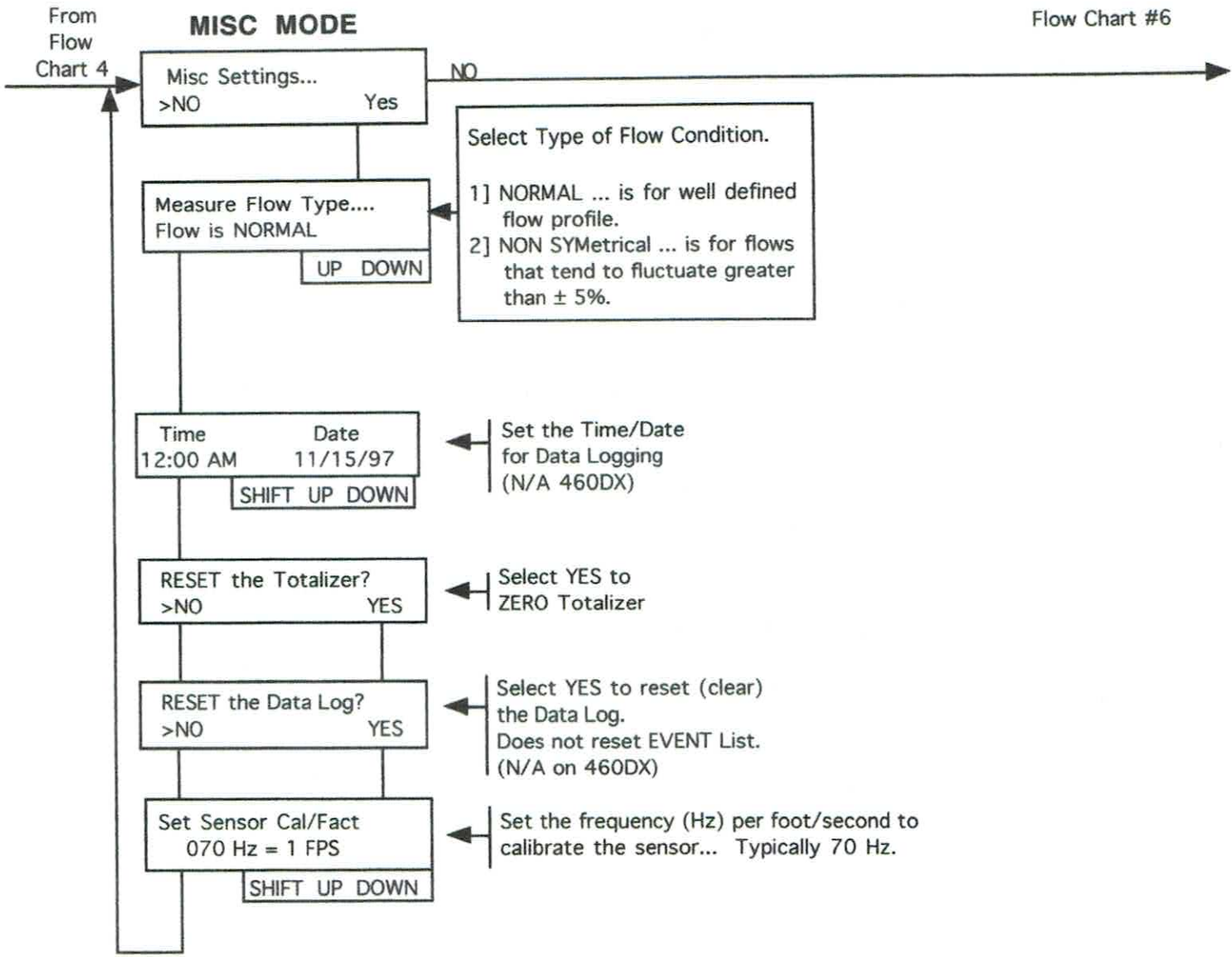

CPS-460 PROGRAM FLOWCHART #6

SET THE 4-20 mA OUTPUTS

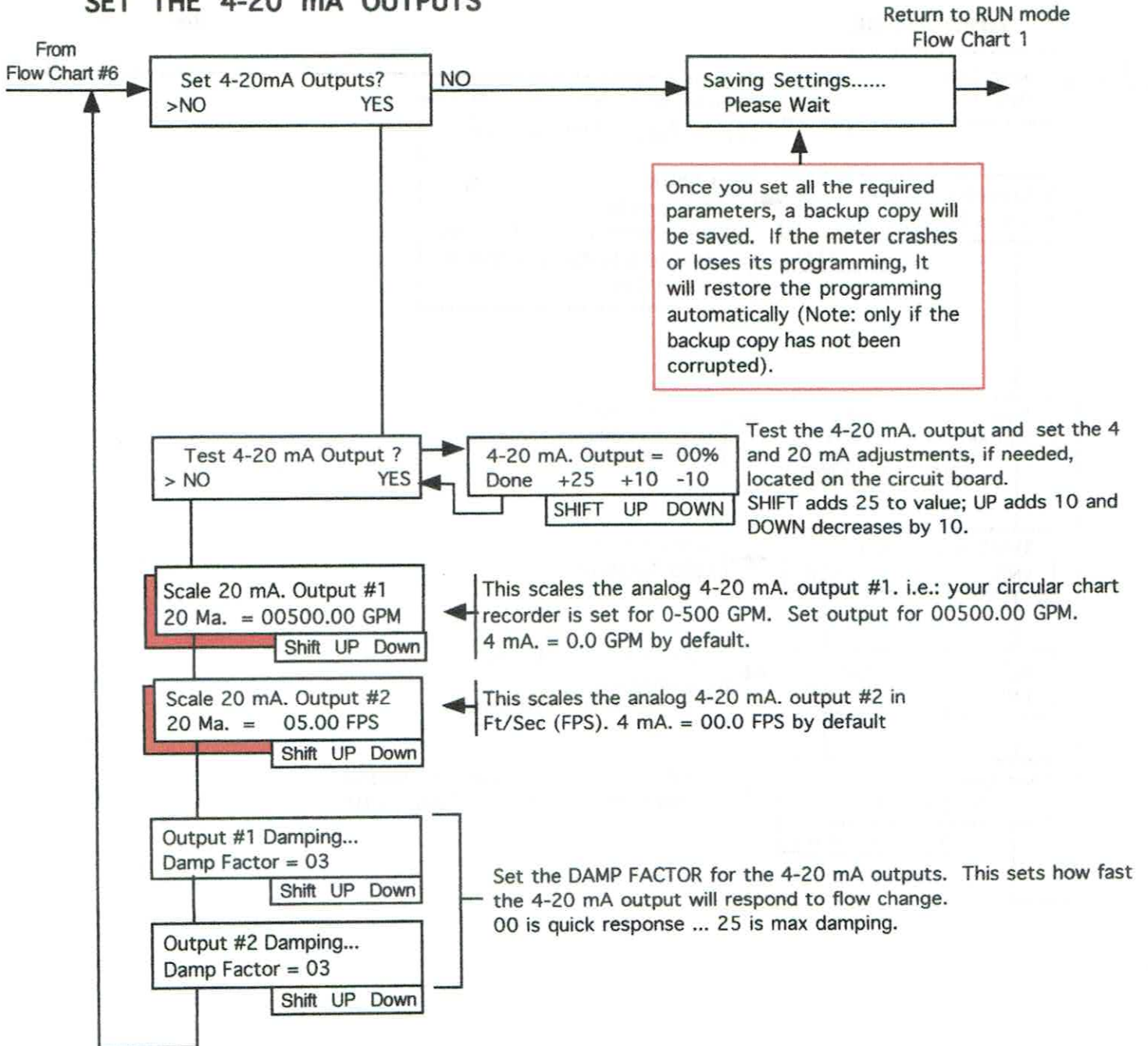

CPS-460 PROGRAM FLOWCHART #7

N/A on 460DX

From
FLOWCHART #1

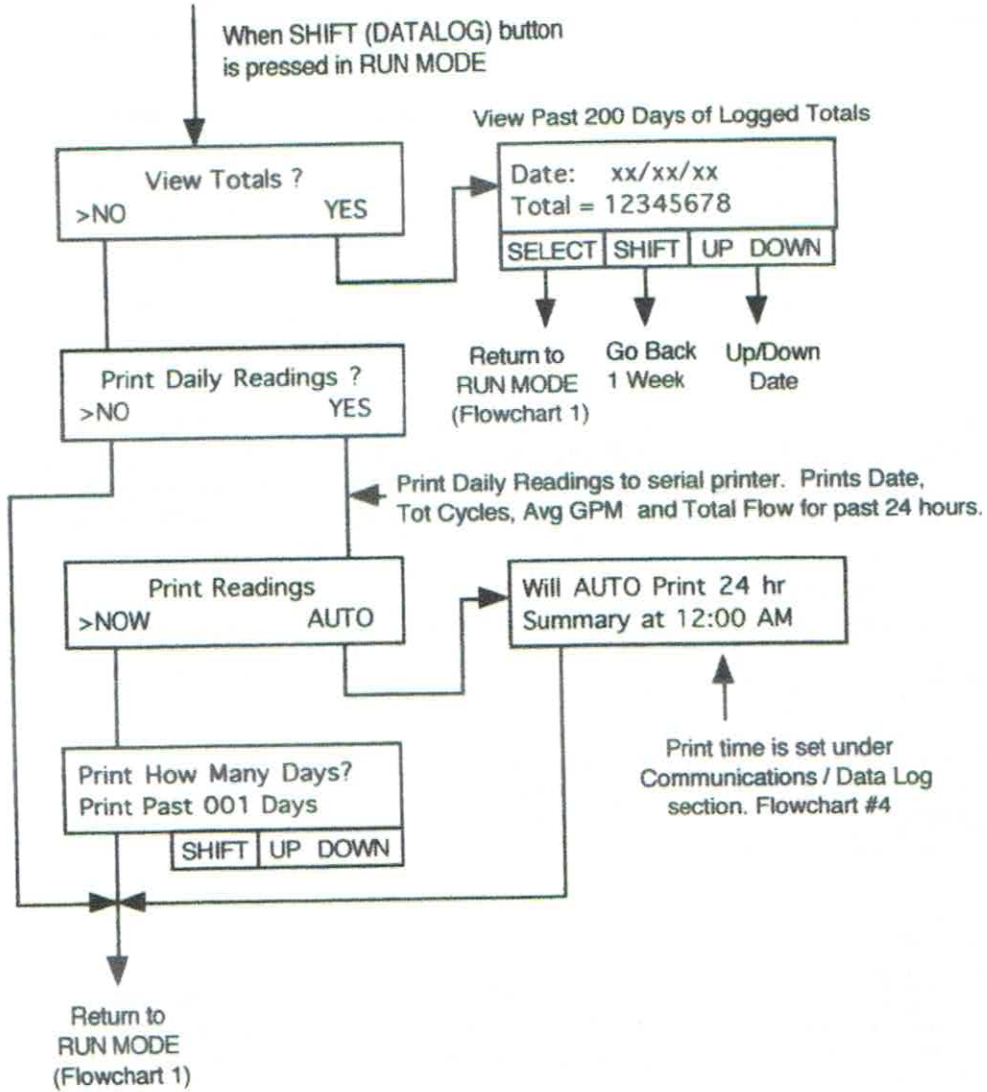

Using the RS232 Communication Output Port (N/A 460DX)

The Operator may choose to communicate with the flowmeter using their PC/Lap Top computer or Modem to download the logged data for further viewing and analysis or view the present status of the flowmeter. This may be accomplished by using any standard communication software package such as Microsofts WINDOWS HYPER-TERMINAL. All data downloaded is in ASCII format. Each line of data is terminated by a CR (carrage return) and line feed. Downloading of flow data may be initiated from the flowmeter using the PRINT function (Press SHIFT when in RUN MODE) or by the PC/ Lap top computer. Connect your communication cable to the RS-232 terminal barrier or RJ11 modular jack (located at bottom right corner of circuit board) and your PC communication port (COM 1 or COM 2) as indicated or Modem (see drawing 100-05).

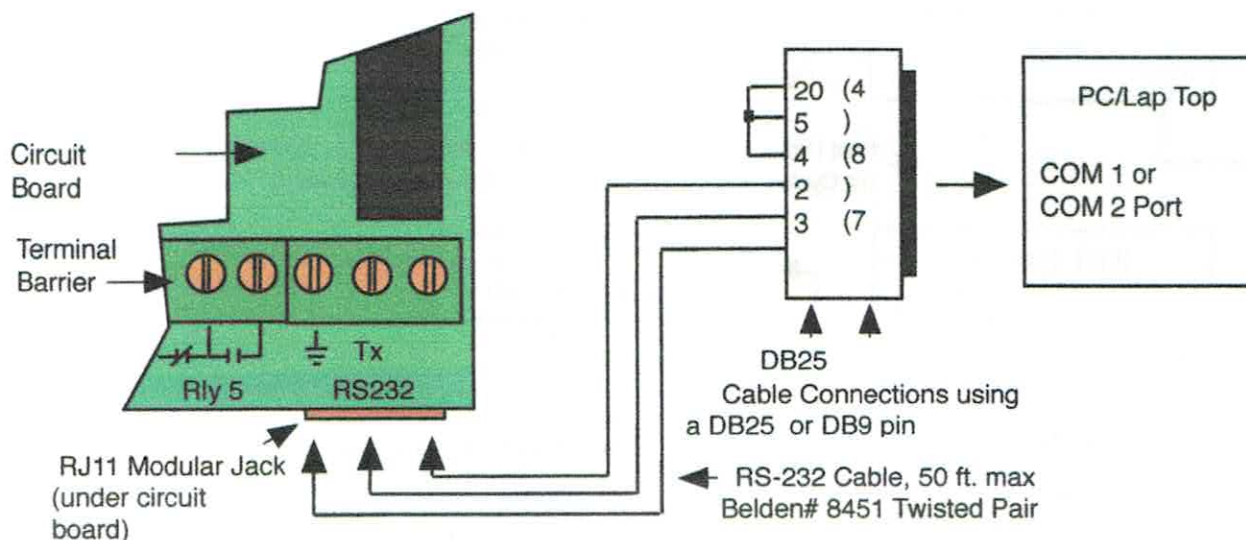

Make the connections shown to a 25 pin or 9 pin cable connector/socket as shown. An RJ11 modular cable with 9 pin adapter to COM 1 or COM 2 port on PC/Lap Top may also be used. Maximum cable length not to exceed 50 feet. If you do not have an RS-232 port, you will need to purchase a RS-232 to USB converter.

In order to successfully download data, you must first match the communication settings in both the flowmeter and the PC. The flowmeter sends data in one of three baud rates - 2400 (default), 9600 baud or 19200. The baud rate is set in the flowmeter by the user under the Set Communications program section. You may set the flowmeter ID# at this time, the Com Address (default = 'A', recommend leaving as 'A') and whether data will be sent to a SERIAL PRINTER, PC/Lap Top or MODEM.

Saving To File

If you like to save the data to a file, you must first set your communication software in the PC to 'begin capture' (under HYPER TERMINAL 'TRANSFER' menu. See your PC/software owners manual for assistance). It is not necessary to 'capture' the data if you only want to view it on the PC/Lap top. You may set the 'begin capture' after the initial 'MENU' from the flowmeter has been downloaded and before making a MENU selection. When Download is completed, select 'Stop capture' under the 'TRANSFER' menu in HYPER TERMINAL.

Communication Settings Using A Modem

You will first need to open WINDOWS HYPER TERMINAL (or other communication software you are using) by selecting: START/PROGRAMS/ACCESSORIES/COMMUNICATIONS/HYPER TERMINAL.

Open HYPER TERMINAL and select if necessary under FILE and PROPERTIES... 'CONNECT USING' and your PC MODEM. Enter phone number etc. for the flowmeter location. (see drawing 100-05 for cable connections).

Communication Settings Using A Direct Connection to COM Port

Same as above (Using A Modem) except under 'CONNECT USING', select 'Direct COM 1 or COM 2', whichever you are connected to with your RS-232 cable. You should set the PC parameters to match the flowmeters baud rate, no parity, 8 bit, 1 stop bit, XON/XOFF disabled (i.e. 2400,N,8,1)

Note: It is necessary to disable all communication 'Flow Control' .
Do Not use XON/XOFF or other hardware handshaking.

Using A Serial Printer

Select SERIAL PRINTER under Set Communications Send DATA to....

This mode is used to send data to a serial printer and is fairly slow, because a 2 second delay is performed by the flowmeter for each line sent to allow the printer time to print the line. Be sure to set the serial printers baud rate to match the flowmeters. See drawing 100-06. Printing of data is initiated from the flowmeter by pressing the SHIFT (Data Log) button while in the Run Mode.

To Initiate Download from a PC/Laptop or Modem:

Connect the communication cable to the RS-232 connector on the Flowmeter to your PC/Lap Top COM port if not using a MODEM. Open your PC communication software (i.e. HYPER TERMINAL), then:

- 1] If Direct Connection...
type SHIFT-'A' (= com addr as set by user - 'A' is default) to get the flowmeters attention.
If using a MODEM...
dial up the flowmeter first. Once connection is made, type SHIFT-'#' or Com Address programmed other than 'A'. 'A' is reserved when using a MODEM.
- 2] Flowmeter should respond with a greeting, model number and a short menu.

Hello!
Control Electronics CPS-460 Flowmeter
Enter Download Selection Type....

- 1] 24 Hour Daily Flow Summary
- 2] Data Entries
- 3] Present Status
- 4] Data Entries with Plot
- 5] Event List
- 6] Reset Data Log
- 7] Terminate Communication
- 8] Show Menu
- 9] Reset Event List

Hit SPACE Bar to interrupt Download.
Your Choice

>

Once communication is established, you may select type of download by typing the number of the selection.

- Selection 1: will download the past 30 to 200 days 24 hour flow summary with DATE, Total Pump Cycles, Total Pump Run Time, AVG GPM Flow Rate and TOTAL Gallons pumped for day.
- Selection 2: will download data entries as logged, time stamped. This download could take a few minutes depending on baud rate and data size.
- Selection 3: this will display the flowmeters present status. GPM, Flow Velocity, Signal Strength and Total gal to date.
- Selection 4: same as number 2, but with plot.
- Selection 5: will download the event list.
- Selection 6: Clears the Data Log and terminates communication with flowmeter.
- Selection 7: terminates communication with flowmeter only. Modem is terminated under HYPER TERMINALS 'CALL' menu and should be performed if Modem is used.
- Selection 8: Show MENU again.
- Selection 9: Clear the EVENT LIST.

Note:

- 1] while the flowmeter is downloading data, the flowmeter may stop flow measurements until download is completed.
- 2] Hit 'SPACE' bar at any time to interrupt the download.
- 3] All downloads begin with the most recent data.
- 4] All downloads begin with a header indicating model#, ID# and date.
- 5] Pressing any key on the flowmeter will terminate communication.

NOTE: USB ports

If your computer or lap top does not have an RS232 COM port, you will need to purchase an RS232 to USB converter. This is available through most office supply stores.

Application Guide Lines For The CPS-460 and 460P Doppler Flowmeter

Doppler Flowmeters are designed to monitor liquid flows containing suspended particles (solids) or entrained air/gas bubbles. Flow velocities, of which the suspended solids will represent, should be in the range of 0.50 to 30.0 fps (feet/second). The flow should be Newtonian in nature with a well defined flow profile for best results. Reynolds numbers greater than 4000 are preferred and is considered a turbulent flow. Flows with less than 4000 Reynolds numbers are considered to be in a transitional condition from turbulent flow to laminar flow (flows of less than 2000 Reynolds number). This usually occurs at low velocities (below 2.0 fps) and can have an affect on both accuracy and retrievability of the flow signal. In the absence of sufficient solids, an aerator device may be used to introduce gas/air bubbles into the flow for improved performance.

Liquid Characteristics

Requirements for best performance are:

- 1] Uniform distribution of suspended particles or gas/air bubbles, 75ppm minimum. Particles/bubbles that tend to accumulate in pockets may cause significant flow errors. This type of flow may be considered non-symmetrical or ERRATIC and require that the user select NON-SYMetrical flow type under MISC SETUP mode in the 460's program.
- 2] Flow should be Newtonian for best results. Non-Newtonian flows may not be measurable. Non-Newtonian flow is a flow in which a non-linear relationship exists between the applied shear stress and the rate of liquid deformation.
- 3] Suspended colloids (non-Newtonian) may not be measurable.
- 4] Suspended particles such as starches or powders may not be good sonic reflectors resulting in poor (erratic) operation. Select NON-SYMetrical flow type under MISC SETUP for this condition, provided you are receiving a flow signal.
- 5] Dissolved solids (salts etc.)are not acceptable.

Problem Areas

Some things to consider and avoid when selecting a site for sensor mounting.

- 1] Low suspended solids in the liquid reduces the amount of sonic reflectors. This is the case with potable water, well water etc. The sensor may have to be located such that the sonic wave is reflected by flow disturbances such as swirls, shear pressure points, vortices etc., created by flanged connections, fully opened valves, elbows, tees etc. Generally the flowmeter will require an in-field calibration 'correction factor' be programmed in the system, but only if you can establish a repeatable flow signal. This type of application is not considered good.
- 2] Avoid venturies, partially closed valves and reduced pipe sections. These cause restrictions to the flow and will increase the flow velocity in their vicinities, causing significant volumetric errors.

I. application guide

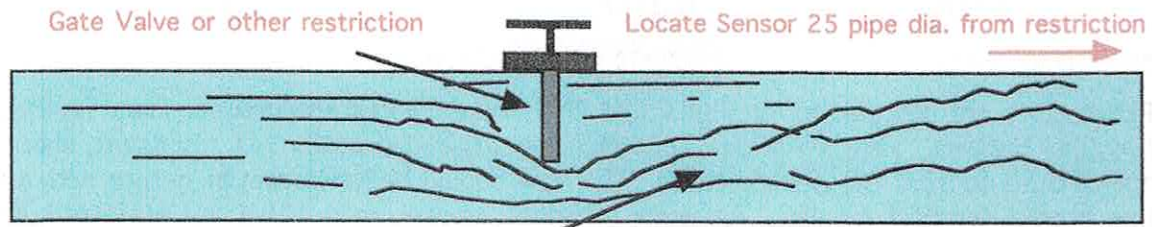

Increased Flow Velocity caused by gate valve or other restriction will cause volumetric errors if flow is monitored in the vicinity of the restriction.

Note: In liquids with low solids (less than 75-100ppm), it may be necessary to find a section of pipe that creates disturbances/turbulence in the flow in order to retrieve a useful flow reading. Finding a good location on the pipe under these circumstances may require some trial and error. In general, it will be necessary that the sensor be located several pipe diameters from the source of the disturbance to allow some diffusion of the disturbance in the flow stream.

- 3] The greater the amount of noise in an application (mechanical and/or electrical) the more solids/bubbles required in the liquid to maintain a good flow reading i.e. good signal-to-noise ratio.

Pipe Considerations

- 1] Pipe must be acoustically compatible. It must allow the high frequency transmit and return signal to pass through the pipe wall and into the flow stream.
- 2] Liner materials tend to insulate and attenuate the ultrasonic signal. This may make it difficult to acquire a flow signal.
- 3] Deposits on the inside pipe wall (i.e. calcium, rust etc.) will both tend to block the flow signal and decrease the pipe ID causing volumetric readings to increase.
- 4] Some liners such as coal tar can result in erroneous readings due to sonic refraction. A calibration factor can be entered in the program to correct under this condition.
- 5] Pipe should be homogeneous. Any breaks in liners or change in pipe wall materials may prevent flow readings from being made.

ACCEPTABLE PIPE MATERIAL

<i>GOOD</i>	<i>OK</i>	<i>PROBLEM</i>
Carbon Steel PVC Stainless Steel Aluminum Ductile Iron	Brass Fiberglass Rigid Plastic Cast Iron Concrete Lined*	Flex Tubing Sleeve Liners Copper Concrete Some Liners

*note: concrete lined pipes can be unpredictable

II. application guide

Measuring Site Considerations

- 1] Piping meets above criteria.
- 2] Measuring point and controller should be located to accommodate the cable length. No attempts should be made to lengthen the sensor cable.
- 3] Site location should avoid potential interference from AC motors, variable speed drives, transformers, radio transmitters (antennas), valves or other restrictions.
- 4] Sensor mounting point should be easily accessible.
- 5] Sensor location should provide at least 10 pipe diameters of straight run. Shorter pipe runs may work fine but may require an in-field calibration by programming a 'calibration factor'.
- 6] Low solids in the flow stream may require moving the sensor closer to elbows or other flow disturbances to acquire a flow reading.
- 7] Mount the sensor on the reduced pipe section when different pipe size sections are encountered.

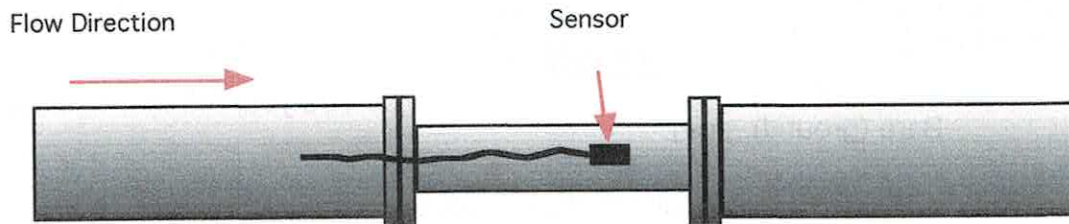

- 8] Mount the sensor at a 3/9 o'clock position on a horizontal pipe (does not apply to vertical pipes). Dual-Head sensors mount across from each other on same horizontal plane. When the pipe size is greater than 12 inches, the sensors may need to be mounted on the same side of the pipe at a 2 and 4 o'clock position.

Sensors On Horizontal Pipe



Single-Head
Sensor



Dual-Head Sensor
under 12" pipe



over 12" pipe

Vertical Pipe

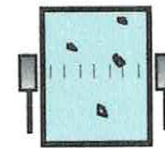

Dual-Head Sensor

- 9] Choose a section of pipe that is always full. Empty pipes can be noisy and partially full pipes with flow will yield erroneous volumetric readings.
- 10] Mount the sensor using the supplied couplant (Silicone Grease). A generous amount should be used to fill all the gaps between the sensor surface and the pipe wall. Use a metal hose clamp (permanent) or duct tape (temporary) to secure the sensor to the pipe. DO NOT over tighten. Lithium grease or zinc oxide may be used as a temporary alternative couplant.

Read Your Instruction Manual!!

III. application guide



CONTROL ELECTRONICS, INC.

P.O. Box 330, Brandamore, PA 19316

(610) 942-3190 Fax: (610) 942-3672

VELOCITY FEET/SECOND TO GALLONS/MINUTE CONVERSION CHART

PIPE ID INCHES (NOMINAL)	VELOCITY IN FEET PER SECOND									
	0.5	1.0	2.0	3.0	4.0	5.0	6.0	8.0	10.0	15.0
	GALLONS PER MINUTE (GPM)									
1	1	2	5	7	10	12	15	20	25	37
1.5	3	6	11	17	22	28	33	44	55	83
2.0	5	10	20	29	39	49	59	78	98	147
2.5	8	15	31	46	61	77	92	123	153	230
3.0	11	22	44	66	88	110	132	176	221	331
4.0	20	39	78	118	157	196	235	314	392	588
5.0	31	61	123	184	245	306	368	490	613	919
6.0	44	88	176	265	353	441	529	706	882	1,323
8.0	78	157	314	470	627	784	941	1,254	1,568	2,352
10	123	245	490	735	980	1,225	1,470	1,960	2,450	3,675
12	176	353	706	1,058	1,411	1,764	2,117	2,822	3,528	5,292
14	240	480	960	1,441	1,921	2,401	2,881	3,842	4,802	7,203
16	314	627	1,254	1,882	2,509	3,136	3,763	5,018	6,272	9,408
18	397	794	1,588	2,381	3,175	3,969	4,763	6,350	7,938	11,907
20	490	980	1,960	2,940	3,920	4,900	5,880	7,840	9,800	14,700
24	706	1,411	2,822	4,234	5,645	7,056	8,467	11,290	14,112	21,168
30	1,103	2,205	4,410	6,615	8,820	11,025	13,230	17,640	22,050	33,075
36	1,588	3,175	6,350	9,526	12,701	15,876	19,051	25,402	31,752	47,628
42	2,161	4,322	8,644	12,965	17,287	21,609	25,931	34,574	43,218	64,827
48	2,822	5,645	11,290	16,934	22,579	28,224	33,869	45,158	56,448	84,672
54	3,572	7,144	14,288	21,433	28,577	35,721	42,865	57,154	71,442	107,163
60	4,410	8,820	17,640	26,460	35,280	44,100	52,920	70,560	88,200	132,300

FLOW FORMULAS

ID in INCHES	Feet/Second (FPS) = GPM ÷ (ID squared x 2.45)
	GPM = ID squared x Velocity (FPS) x 2.45
ID in Milli-meters	MPS = LPM ÷ (ID squared x .04712)
	LPM = ID squared x MPS x .04712

STEEL, STAINLESS STEEL, PVC

STANDARD SCHEDULES
INSIDE DIAMETERS

SIZE INCH	SCH 5	SCH 10 (LT WALL)	SCH 20	SCH 30	STD.	SCH 40	SCH 60	X STG	SCH 80	SCH 100	SCH 120	SCH 140	SCH 180	O.D.
1	1.185	1.097			1.049	1.049		0.957	0.957				0.185	1.315
1.25	1.53	1.442			1.380	1.380		1.278	1.278				1.160	1.660
1.5	1.77	1.682			1.610	1.610		1.500	1.500				1.338	1.900
2	2.245	2.157			2.067	2.067		1.939	1.939				1.687	2.375
2.5	2.709	2.635			2.469	2.469		2.323	2.323				2.125	2.875
3	3.334	3.260			3.068	3.068		2.900	2.900				2.624	3.500
3.5	3.834	3.760			3.548	3.548		3.364	3.364				3.438	4.000
4	4.334	4.260			4.026	4.026		3.826	3.826		3.624		4.313	4.500
5	5.345	5.295			5.047	5.047		4.813	4.813		4.563		5.187	5.563
6	6.407	6.357			6.065	6.065		5.761	5.761		5.501			6.625
8	8.407	8.329	8.125	8.071	7.981	7.981	7.813	7.625	7.625	7.437	7.187	7.001	6.813	8.625
10	10.482	10.42	10.25	10.13	10.02	10.02	9.750	9.750	9.562	9.312	9.062	8.750	8.500	10.75
12	12.420	12.39	12.25	12.09	12.00	11.938	11.626	11.75	11.37	11.06	10.75	10.50	10.12	12.75
14		13.50	13.37	13.25	13.25	13.124	12.814	13.00	12.50	12.31	11.81	11.50	11.18	14.00
16		15.50	15.37	15.25	15.25	15.000	14.688	15.00	14.31	13.93	13.56	13.12	12.81	16.00
18		17.50	17.37	17.12	17.25	16.876	16.564	17.00	16.12	15.68	15.25	14.87	14.43	18.00
20		19.50	19.25	19.25	19.25	18.814	18.376	19.00	17.93	17.43	17.00	16.50	16.06	20.00
24		23.50	23.25	23.25	23.25	22.626	22.126	23.00	21.56	20.93	20.93	19.87	19.31	24.00
30		29.37	29.00	29.00	29.25	29.250		29.00						30.00
36		35.37	35.00	35.00	35.25	35.25		35.00						36.00
42					41.25	41.25		41.00						42.00
48					47.25	47.25		47.00						48.00

DUCTILE IRON PIPE STANDARD CLASSES (INSIDE DIAMETERS)

SIZE INCH	OUTSIDE DIAMETER INCH	CLASS 50	CLASS 51	CLASS 52	CLASS 53	CLASS 54	CLASS 55	CLASS 56	CEMENT LINING	
									STD THICKNESS	*DOUBLE THICKNESS
3	3.96		3.46	3.40	3.34	3.28	3.22	3.16		
4	4.80		4.28	4.22	4.16	4.10	4.04	3.98		
6	6.90	6.40	6.34	6.28	6.22	6.16	6.10	6.04	.125	.250
8	9.05	8.51	8.45	8.39	8.33	8.27	8.21	8.15		
10	11.10	10.52	10.46	10.40	10.34	10.28	10.22	10.16		
12	13.20	12.58	12.52	12.46	12.40	12.34	12.28	12.22		
14	15.30	14.64	14.58	14.52	14.46	14.40	14.34	14.28		
16	17.40	16.72	16.66	16.60	16.54	16.48	16.42	16.36		
18	19.50	18.80	18.74	18.68	18.62	18.56	18.50	18.44	.1875	.375
20	21.60	20.88	20.82	20.76	20.70	20.64	20.58	20.52		
24	25.80	25.04	24.98	24.92	24.86	24.80	24.74	24.68		
30	32.00	31.22	31.14	31.06	30.98	30.90	30.82	30.74		
36	38.30	37.44	37.34	37.06	37.14	37.04	36.94	36.84		
42	44.50	43.56	43.44	43.32	43.20	43.08	42.96	42.84	.250	.500
48	50.80	49.78	49.64	49.50	49.36	49.22	49.08	48.94		
54	57.10	55.96	55.80	55.64	55.48	55.32	55.16	55.00		

** REDUCE I.D. BY DIMENSION SHOWN - THESE FIGURES APPLY ALSO TO C.I. PIPE.

CPS-460 Doppler Troubleshooting Guide

Symptom	Cause	Check or Try
<p>#1 No display and/or backlighting</p> <p>No Power Light</p>	<p>No Power</p> <p>Defective Display</p>	<p>-Check power circuit breaker and wiring</p> <p>-Check ON/OFF switch on main circuit board</p> <p>-Ribbon cable not secure</p> <p>-0.5 amp fuse on main circuit board</p>
<p>#2 Keypad Does Not Respond</p>	<p>Ribbon Cable</p> <p>Lightning or Power surge</p>	<p>-Check ribbon cable</p> <p>-Turn Power OFF for 10 seconds. then back ON</p> <p>-RESET meter</p>
<p>#3 4-20 mA. Output Not Functioning and/or Indicates Max All The Time</p> <p>Output Not Same As Display</p>	<p>Defective Wiring</p> <p>Defective Output and/or Lightning Damage</p> <p>Not Scaled Correctly</p>	<p>-Check wiring and polarity</p> <p>-Disconnect output wires and check 4-20 with current meter. If OK, receiver or wiring is problem.</p> <p>-Replace Q1 and/or Q2 (2N3904 transistor) and U1 (LM324 IC) on main circuit board.</p> <p>-Go to programming, 'SET 4-20mA OUTPUTS' and 'TEST /SCALE 4-20mA OUTPUT'</p>
<p>#4 Display Does Not Change or Update</p>	<p>Processor Crash</p> <p>Lightning or Power Surge</p>	<p>-Turn Power OFF for 10 seconds. then back ON</p> <p>-RESET meter</p>
<p>#5 Flowmeter keeps trying to restart</p>	<p>Processor Crash</p> <p>Lightning or Power Surge</p>	<p>RESET meter</p>
<p>#6 Pass Code Lockout</p>	<p>Wrong Code</p> <p>Code Corrupted</p>	<p>Call Factory for alternate code</p> <p>Provide product SN#..... Call (610) 942-3190</p>
<p>#7 No Flow Signal When There Is Flow In The Pipe</p> <p>LED Flow Indicator Does Not Come ON With Flow - (located on Doppler input circuit board)</p>	<p>Sensor Not Aligned Correctly</p> <p>Couplant Paste Missing or Aging (drying - shrinking)</p> <p>Accoustic Signal Path Obstructed</p> <p>Sensor Wiring Incorrect</p> <p>THRESHOLD Adjustment Set Too High</p> <p>Defective Sensor or Doppler Input Card</p> <p>Poor Application</p>	<p>-Check Sensor mounting. Make sure mounting strap is not too tight.</p> <p>-Replace couplant (silicone grease) between sensor and pipe wall if shrinking or drying out.</p> <p>-Check for signal path obstruction - i.e. Concrete or other pipe lining that may be too thick or is pulling away from inside pipe wall - Use spool section if needed.</p> <p>-Check wire connections to terminal barrier for correct polarity.</p> <p>-THRESHOLD setting on Doppler input circuit board may be set too high. CW increases - do not adjust more than 1/2 to 3/4 of its turn from the full CCW position. This could cause loss of flow signal.</p> <p>-Test sensor response by moving sensor faces back and forth closely toward each other (dual-head) - LED flow indicator should blink or light.</p> <p>-Try small adjustments to CABLE ADJ and/or L3 receivers tuning coil on Doppler Card.</p> <p>-Verify your application is suitability for Doppler Flowmeters.</p>

CPS-460 Doppler Troubleshooting Guide

Symptom	Cause	Check or Try
#8 No Flow Indication But LED Flow Indicator Light Comes ON	Programming Error	<ul style="list-style-type: none"> -Check programming of LOW FLOW SHUT OFF setting. If setting is higher than flow rate velocity, meter will indicate ZERO flow. -Check ZERO IF SIG STRENGTH IS LESS THAN setting. - typically set for 10 to 20%. Too high may ZERO meter.
#9 Readings Fluctuate More Than 0.40 FPS (this is not necessarily a problem)	<p>Too Many Air Bubbles</p> <p>Suspended Solids Are Too High (>20%) or Too Low (<50ppm) or intermittent</p> <p>Poor Sensor Mounting or Old Couplant Paste</p> <p>Low Flow Velocity (<1.5 FPS)</p>	<ul style="list-style-type: none"> -Reduce Source of too many air bubbles or high solids content. -Check sensor mounting and couplant paste. -Increase programmed DAMP FACTOR - best setting is 5, increase if necessary. -Increase AVERAGE READINGS in program -Check if flow is fluctuating (i.e. check valve is bouncing due to low flow) -Change 'MEASURE FLOW TYPE' to NON-SYM -Increase flow velocity (recommend >1.50 FPS)
#10 Readings Are Fixed or MAX All The Time Readings Go To MAX Intermittently	<p>Poor Sensor Mounting or Old Couplant Paste</p> <p>Electrical Noise Interference</p> <p>Interference from close proximity of other Doppler flowmeters</p> <p>Variable Speed Drive (VFD) Interference</p>	<ul style="list-style-type: none"> -Check Sensor mounting and couplant paste. -Increase THRESHOLD setting on Doppler input card - CW increases (do not adjust more than 1/2 to 3/4 of its turn from the full CCW position) -Decrease (CCW) Blue GAIN potentiometer -Increase LOW PASS FILTER adjustment on Doppler input card - CW increases. -Increase 'SIGNAL FILTERING %' in program. (caution: too high % may cause loss of flow signal) -Relocate flow meter to distance itself from electrical wiring, other Doppler flowmeters and variable speed drives.
#11 Flow Readings Not Correct	<p>Programming Incorrect</p> <p>Your Flow Data Source Incorrect</p> <p>Valve(s) not opened</p> <p>Sensor Location Poor</p> <p>Noise Interference</p>	<ul style="list-style-type: none"> -Check programming, particularly the pipe ID setting -Verify pump flow rates, valves partially closed etc. -Check sensor is located 10 pipe diameters downstream from elbows, tees etc.... 20 diameters from reducers, valves etc. (note: partly closed valve seriously distorts the flow profile) -Variable Speed Drive noise - see symptom #10 -If readings are repeatable, program a 'SITE CAL FACTOR' for in-field calibration correction.
#12 Flow Readings ZERO At Lower Flows	<p>LOW FLOW SHUT OFF Programmed Too High</p> <p>Flow Velocity Is Too Low</p> <p>Low Signal Strength</p>	<ul style="list-style-type: none"> -Check LOW FLOW SHUT OFF program setting -Flow Velocities of less than 1.5 FPS may be difficult to monitor. Increase velocity or reduce pipe size at sensor location. -Check ZERO IF SIG STRENGTH IS LESS THAN setting. Too high may ZERO flow, especially at low flows which typically have low signal strength.
#13 Flow Readings When There Is No Flow	<p>Noise Interference</p> <p>Poor Sensor Mounting or Old Couplant Paste</p>	<ul style="list-style-type: none"> -Try small adjustments to L3 coil on Doppler Card -Increase LOW FLOW SHUT OFF and/or 'ZERO IF SIGNAL STRENGTH IS LESS THAN' in program -See symptom #10

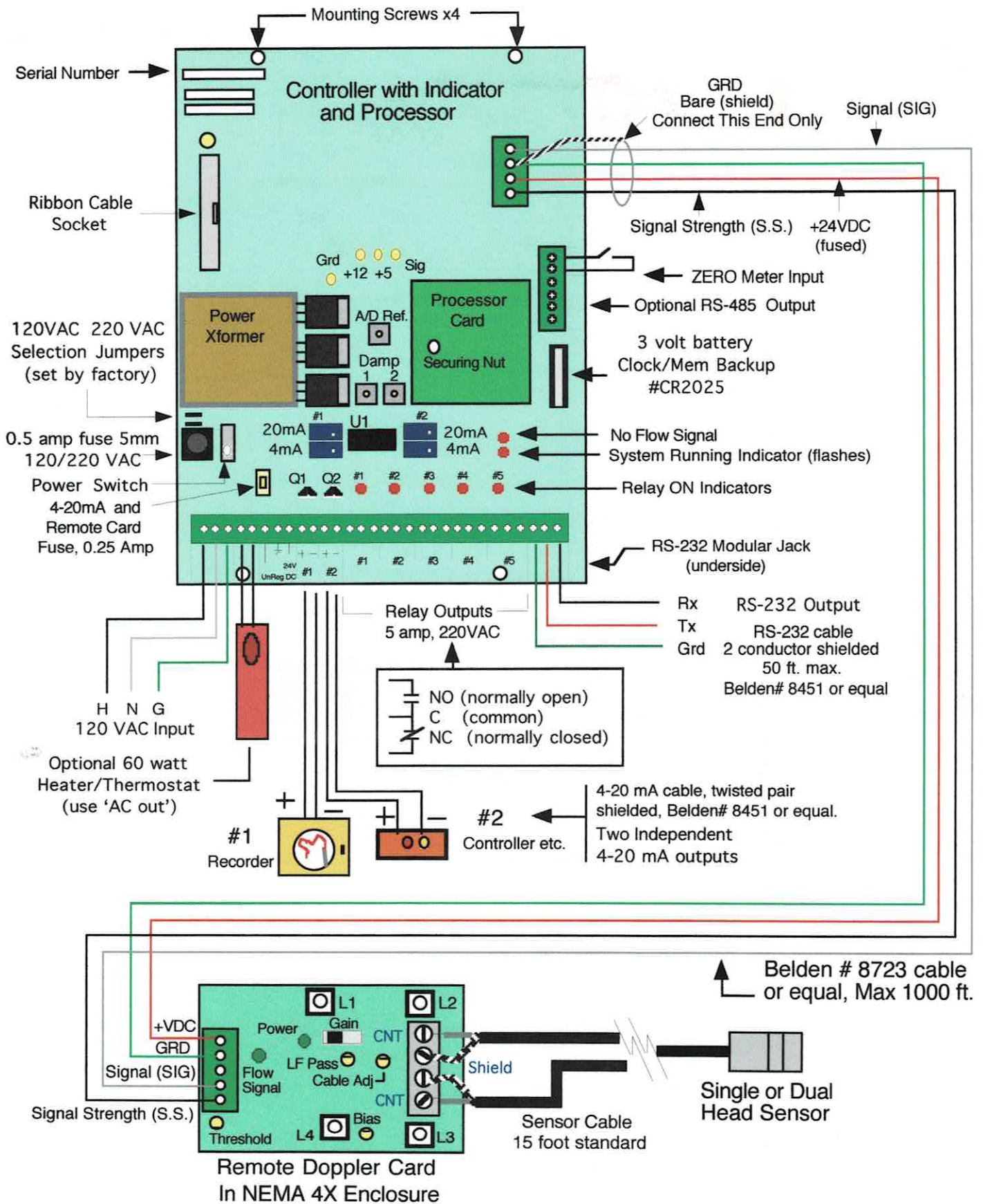

CPS-460R Wiring Interconnect Diagram